



# SANY

Quality Changes the World



## **SANY CRAWLER CRANE** **SCC 1350E**

# CRAWLER CRANE

## cont ent

### P3

#### SCC1350E Crawler Crane

- Basic size of overall crane
- Main technical characteristics
- Performance parameter
- Transportation dimension
- Transport program
- Schematic diagram of disassembly

### P12

#### Detailed introduction

- Upperworks
- Lowerworks
- Operation equipment
- Safety device

### P19

#### Combination of Operating Modes

- Working condition combination
- Boom H working condition
- Fixed jib FJ working condition

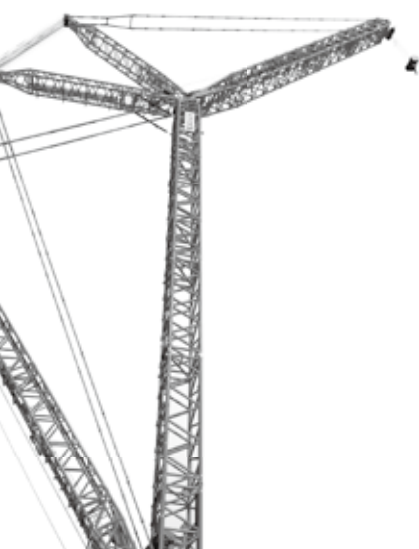

# SCC1350E

03	Basic size of overall crane
04	Main technical characteristics
05	Performance parameter
06	Transportation dimension
09	Transport program
10	Schematic diagram of disassembly



## Basic size of overall crane

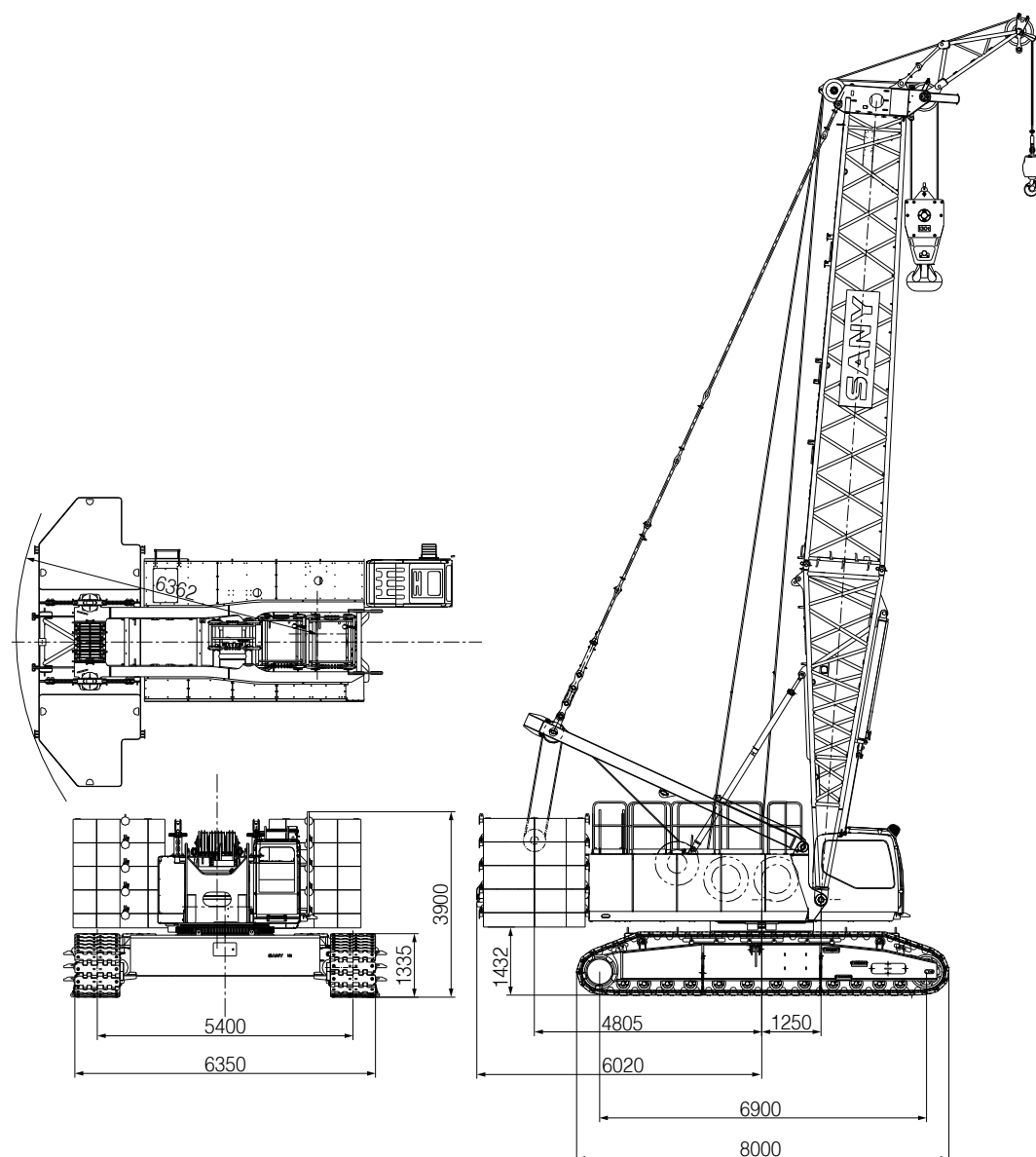

## Main technical characteristics

### 1. Powerful lifting capacity

For the main boom, the maximum lifting capacity is 140t, the maximum lifting moment is  $95.4t \times 7m = 668t \cdot m$ , and the maximum length is 80m. For the fixed jib, the maximum lifting capacity is 30t, and the longest combination is 65m+31m.

### 2. Global transportation standard

The basic crane is 32.8t in transport weight and 3m in transport breadth, and saves the transportation cost.

### 3. Most economical transportation mode

Transported by 5 vehicles (80m boom+31m jib).

### 4. Efficient self-assembly technology

Capable of achieving self-assembly of basic crane; capable of achieving self-assembly of crawler frame, central ballast, counterweight and boom system. The self-assembly time is less than 7h.

### 5. Special function application (optional)

The main and auxiliary hooks operate simultaneously.

S of slewing area limiting technology

Limiting technology of boom system working area

### 6. Calibration-free technology of load moment limiter

No need for recalibration during switching of the working condition. The construction is more efficient, and it is more convenient to use.

### 7. Safe control system

It has operation and installation modes, thus being convenient and reliable; it is equipped with the electronic level meter for real-time display; it has the functions, such as off-line stop, emergency electric control, lightning protection, automatic reversing while traveling and closed-circuit monitoring, and a complete safety and monitoring system.

### 8. Excellent operating performance

The load sensing, ultimate load regulation and electro-hydraulic proportional dead slow control ensures excellent micro-motion of each action, and smoother operation.

### 9. Strong power supply

The third-stage emission engine of SDEC has 251KW power and is powerful and low-carbon.

### 10. Reliable function guarantee

The key parts are products of well-known brands; the structure design and mechanism design are safe and reliable; the control system can run steadily in arctic-alpine, high-temperature, highland and harsh sandstorm environments.

### 11. Wide adaptability

Comply with the certification of CE, North America, Australia, Russia and Taiwan, and third-stage off-road emission standard in Europe and America, and can be widely used in the industries such as shipbuilding, subway, thermal power, municipal engineering, and metallurgy.

### 12. More optional functions

Optional luffing jib working condition.

Optional double-free fall.

Optional counterweight self-assembly.

Optional fuel and hydraulic oil heating device.

Optional high-pressure alarm system.

Optional automatic forward function.

## Performance parameter

Main performance parameters of SCC1350E crawler crane			
Performance Index		Unit	Parameter
Working condition of boom	Maximum lifting capacity	t	140
	Maximum rated lifting moment	t·m	668
	Length of boom	m	17-80
	Boom luffing angle	°	15° -86°
Working condition of fixed jib	Maximum lifting capacity	t	30
	Length of jib	m	13-31
	Longest boom+jib combination	m	65+31
Operating speed	Boom to jib angle	°	15° and 30°
	Main hoisting rope speed	m/min	0-140
	Auxiliary hoisting rope speed	m/min	0-140
	Boom luffing speed (boom angle from 15° to 86°)	s	90
	Slewing speed	rpm	0-2.2
	Traveling speed	km/h	0-1.3
Engine	Gradeability	-	30%
	Output power	kW	251
Transportation parameters	Rated speed	rpm	2200
	Maximum single piece transportation weight (including base)	t	32.8
	Transportation dimension (length × breadth × height)	m	14.42×3.0×3.26
	Average ground bearing pressure	MPa	0.116

## Transportation dimension

<b>Carbody (including base)</b>	×1
Length (L)	14.42m
Breadth (B)	3.00m
Height (H)	3.26m
Weight	32.8t
<b>Crawler assembly</b>	×2
Length (L)	8.00m
Breadth (B)	1.37m
Height (H)	1.33m
Weight	14t
<b>Boom base</b>	×1
Length (L)	7.21m
Breadth (B)	2.23m
Height (H)	2.11m
Weight	2.71t
<b>Boom tip</b>	×1
Length (L)	10.55m
Breadth (B)	2.11m
Height (H)	2.77m
Weight	2.79t
<b>3m boom intermediate section</b>	×1
Length (L)	3.14m
Breadth (B)	2.23m
Height (H)	1.87m
Weight	0.63t
<b>6m boom intermediate section</b>	×4
Length (L)	6.14m
Breadth (B)	2.23m
Height (H)	1.87m
Weight	1.06t
<b>12m boom intermediate section</b>	×3
Length (L)	12.14m
Breadth (B)	2.23m
Height (H)	1.87m
Weight	1.96t

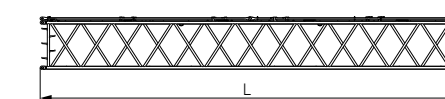
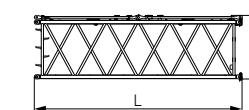
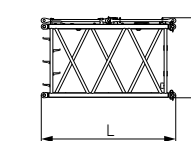
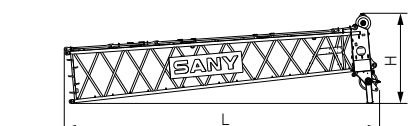
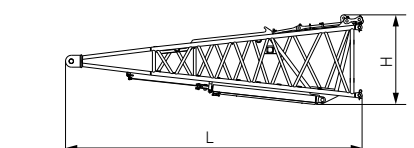
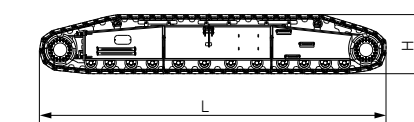
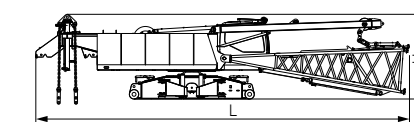



## Transportation dimension

<b>Boom extension</b>	×1
Length (L)	2.36m
Breadth (B)	1.04m
Height (H)	0.98m
Weight	0.3t
<b>Fixed jib base (including spreader)</b>	×1
Length (L)	5.25m
Breadth (B)	1.19m
Height (H)	1.30m
Weight	0.84t
<b>Fixed jib tip</b>	×1
Length (L)	5.43m
Breadth (B)	1.01m
Height (H)	0.99m
Weight	0.53t
<b>3m boom intermediate section</b>	×1
Length (L)	3.12m
Breadth (B)	1.02m
Height (H)	0.92m
Weight	0.19t
<b>6m boom intermediate section</b>	×3
Length (L)	6.12m
Breadth (B)	1.02m
Height (H)	0.92m
Weight	0.34t
<b>Central ballast</b>	×2
Length (L)	4.00m
Breadth (B)	1.24m
Height (H)	0.97m
Weight	10.00t
<b>Counterweight tray</b>	×1
Length (L)	6.08m
Breadth (B)	2.38m
Height (H)	1.29m
Weight	10.00t

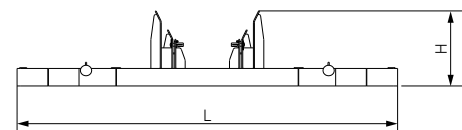
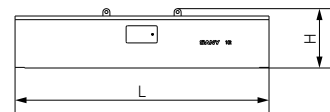
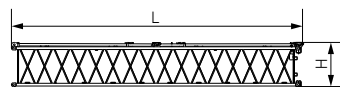
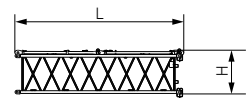
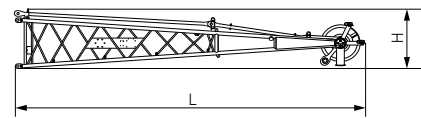
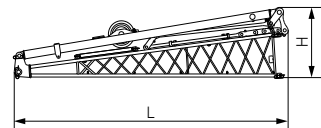
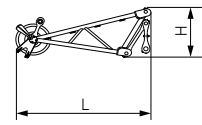

## Transportation dimension

<b>Counterweight</b>	(1+1)×4
Length (L)	1.94m
Breadth (B)	2.33m
Height (H)	0.60m
Weight	5.50t
<b>130T lifting hook</b>	×1
Length (L)	2.28m
Breadth (B)	0.82m
Height (H)	0.75m
Weight	1.8t
<b>80T lifting hook</b>	×1
Length (L)	2.13m
Breadth (B)	0.82m
Height (H)	0.62m
Weight	1.57t
<b>35T lifting hook</b>	×1
Length (L)	1.88m
Breadth (B)	0.82m
Height (H)	0.46m
Weight	1.08t
<b>13.5T ball hook</b>	×1
Length (L)	0.95m
Breadth (B)	0.43m
Height (H)	0.43m
Weight	0.47t

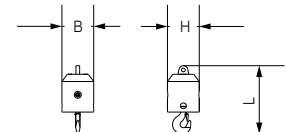
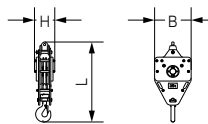
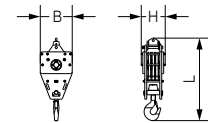
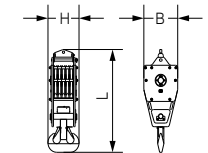
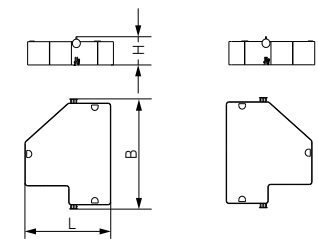

Notes:

1. It's a schematic diagram of transport dimension of the spare part, which is not drawn to scale. The marked dimension is the design value, excluding the packaging.
2. The weight is a design value, and may be slightly different due to the manufacturing error.

## Transport program

Basic crane (three winches, base, outrigger, mast and all wire ropes) and base  
Total: 32.8t

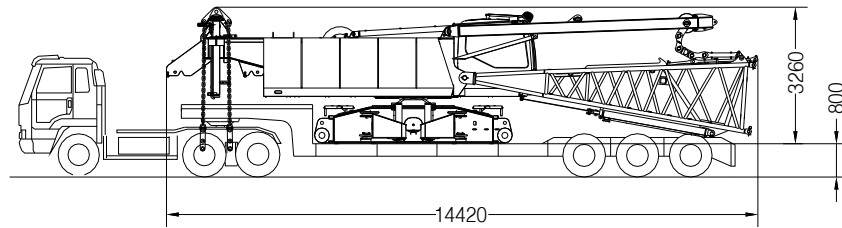

Crawler frame\*2: 28t  
12m boom: 1.96t  
6m boom: 1.06t  
6m fixed jib: 0.34t  
Boom extension: 0.3t  
Packing case: 1t  
Total: 32.26t

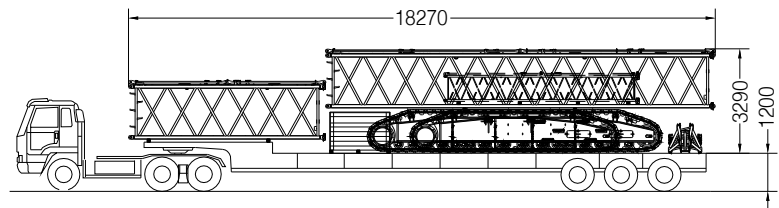

Counterweight tray: 10t  
Counterweight\*2: 11t  
Boom tip: 2.79t  
6m boom: 1.06t  
3m boom: 0.63t  
Fixed jib base: 0.84t  
Rear pendant bar of jib: 0.15t  
Total: 26.47t

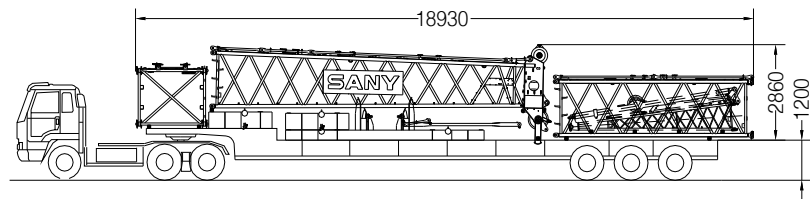

Counterweight block: 5.5t  
Central ballast\*2: 20t  
12m boom: 1.96t  
6m boom: 1.06t  
6m fixed jib: 0.34t  
Fixed jib tip: 0.53t  
130T lifting hook: 1.8t  
80T lifting hook: 1.57t  
35T lifting hook: 1.08t  
13.5T lifting hook: 0.47t  
Total: 34.31t

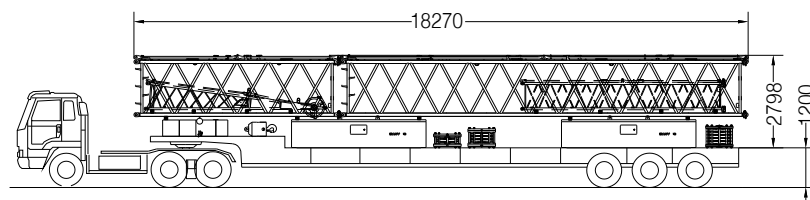

Counterweight block\*5: 27.5t  
12m boom: 1.96t  
6m boom: 1.06t  
6m fixed jib: 0.34t  
3m fixed jib: 0.19t  
Total: 31.05t

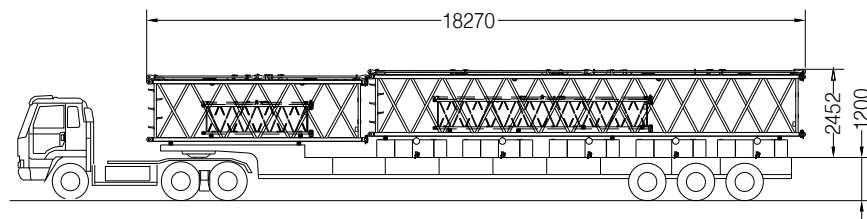

## Schematic diagram of disassembly

### 1) Self-assembly of basic crane

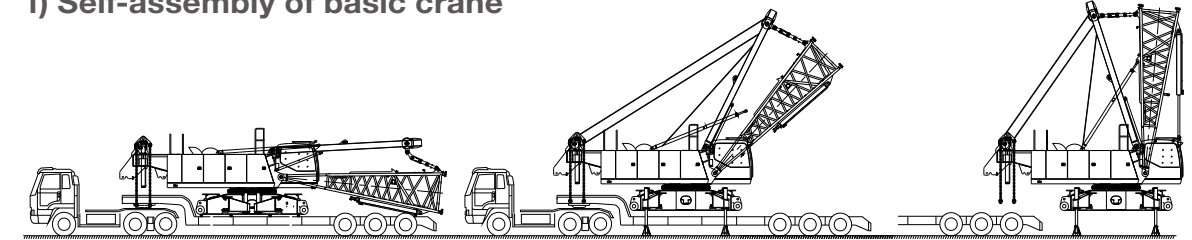

### 2) Self-assembly of crawler frame

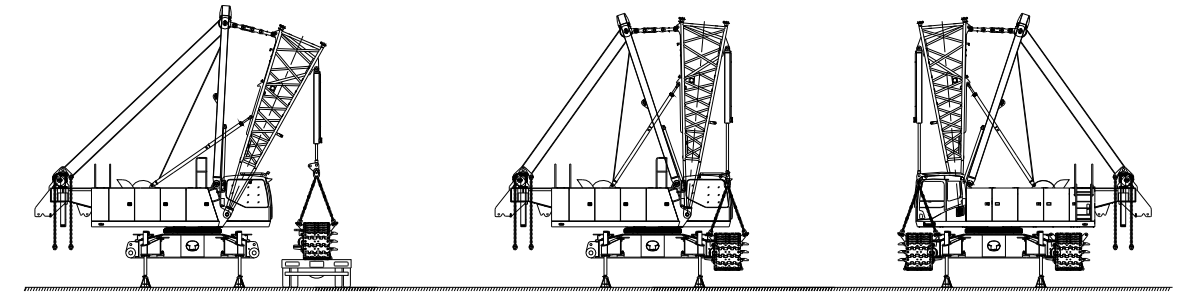

### 3) Self-assembly of central ballast

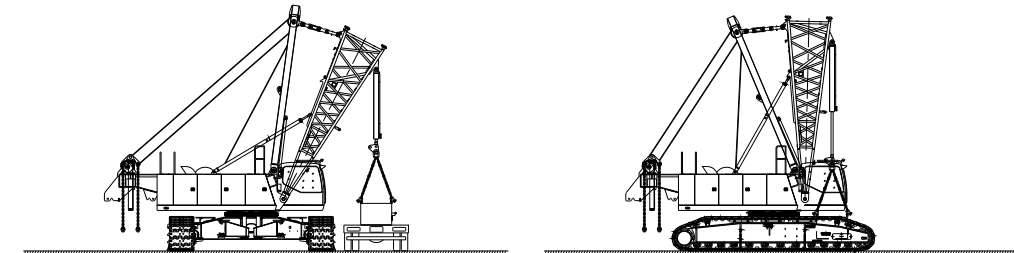

### 4) Self-assembly of counterweight

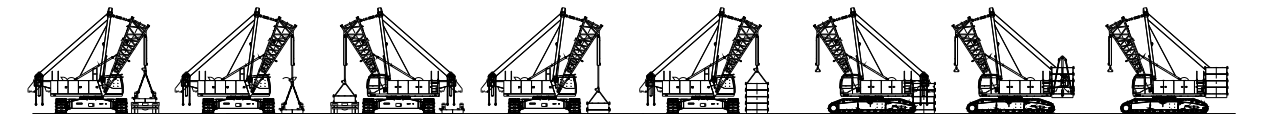

### 5) Self-assembly of boom



# SCC1350E

Upperworks	12
Lowerworks	14
Operation equipment	15
Safety device	16

## Detailed introduction Upperworks

### 1) Engine

- SC9DF340Q3 in-line six-cylinder, four-stroke, water-cooled, turbo charged and intercooled electronic control diesel engine of SDEC have 251kW rated power and 2200rpm rated speed. The maximum output torque is 1,430Nm/1,400rpm.
- It complies with the third-stage non-road emission standard.
- Fuel tank: the volume is 400L, and the fuel capacity is shown by oil pointer and electronically.

### 2) Electrical control system

- It employs the advanced central control unit, torque limiter, display, sensor and closed-circuit monitoring system.
- Reliability: the main electrical devices are products of the international or intra-industry famous brands, and can run steadily in arctic-alpine, high-temperature, highland and harsh sandstorm environments.
- Safety: the electrical design fully meets the CE standard, with complete multistage safety limit control and safety signal indications.
- Comfort: all electrical parameters can be seen through the combination instrument in the cab, and the working parameters and working condition are monitored in real time.
- Advancement: the electrical CAN bus system constitution of the overall crane, limit load control of load power, redundant communication check, and optional global positioning.

### 3) Hydraulic system

- The hydraulic system includes: main valve hydraulic system, main hoist hydraulic system, boom luffing hydraulic system, auxiliary hydraulic system, etc.
- Feature: the main system is an open circuit and widely employs electronic proportional control elements. The system is a load-sensitive LUDV system, can achieve the flow distribution irrelevant to the load, employs the hydraulic proportional pilot control and is sensitive in operation and good in micro-motion.

### 4) Main and auxiliary hoisting devices

- The variable motor of hoisting mechanism can steplessly adjust the winch speed according to the lever control signal and automatically control the motor displacement according to the load condition to achieve the automatic balance between safety and speed of the winch.
- The variable hydraulic motor of hoisting mechanism can automatically adjust the displacement according to the load to achieve the maximum winch speed.
- It employs the high-quality anti-rotating wire rope, with high hoisting safety and long service life.

#### Main hoisting device

Rope speed of outermost working layer	0-140m/min
Diameter of wire rope	26mm
Length of wire rope of main winch	360m
Rated single rope pulling force	12t

#### Auxiliary hoisting device

Rope speed of outermost working layer	0-140m/min
Diameter of wire rope	26mm
Length of wire rope of auxiliary winch	260m
Rated single rope pulling force	12t

### 5) Boom luffing device

- The boom luffing drum has the pawl and ratchet locking device to ensure the placement safety of boom in non-operating state.

#### Boom luffing device

Boom from 15° to 86°	90s
Diameter of wire rope	20mm
Length of boom luffing wire rope	270m
Rated single rope pulling force	7.8t

### 6) Slewing mechanism

- It employs three-row roller slewing bearing, and large-displacement single-motor reduction gear drive; the slewing speed is 0-2.2r/min; it has the function of neutral-position free slipping and can provide 360° slewing. When the hand lever is in neutral position, and the slewing speed is 0, the brake is off, and the slewing mechanism is in lock state and is provided with a locking device. When traveling while hoisting, or transporting, avoid the slewing impact of the upper part.

### 7) Counterweight

- Central ballast: 2 in total, and total weight: 20t (10t×2)
- Counterweight: 5.5t counterweight block, 8 in total, a 10t counterweight tray, and total weight: 54t.

### 8) Cab

- The newly designed fully-enclosed broad-vision cab with SANY unique style is provided with adjustable seat and air conditioner.
- It has four headlamps to provide lighting for long and short distances.
- With large glass windows, and rearview mirrors, the vision is wider.
- The armrest box can be adjusted forward and backward with the seat, is comfortable to operate and accords with man-machine engineering principle.

### 9) Control operation

- The traveling system has automatic forward function (optional), i.e., no matter how the upperworks slew, the upperworks are always the forward direction of operator.
- The actions of main winch, auxiliary winch, luffing device and slewing mechanism are controlled by switching the functions of control lever;
- The operating buttons, control switch, air conditioning control panel, etc. are distributed on the left and right armrest boxes to achieve its different control functions.

### 10) Alarm display

- When all alarm information, including wind speed, coolant temperature, oil temperature, fuel capacity, oil pressure, working time, engine revolution, etc., is faulty, they will be shown on display screen in the cab and, a sound-light alarm is given simultaneously.

## Lower works

### 1) Travel drive device

- Each crawler has an independent travel drive device. The hydraulic travel motor drives the planet gear speed reducer to achieve independent travel by transmission from the driving wheel.

### 2) Travel brake

- Travel brake is a normally closed brake installed in the reducer, which can carry out compensation automatically and is not required to be adjusted. The brake is released when stepping on the control pedal valve, thus achieving travel.

### 3) Crawler pad

- Crawler pad is made from the material with high strength and high wear resistance, and its tension can be adjusted by hydraulic jack after installed on the equipment. The ideal tension can be achieved by adjusting the position of the shim plate.

### 4) Base

- The drive power pin of hydraulic cylinder is connected with the crawler frame, which is convenient for the installation and dismantling. It employs high-strength steel welding frame structure.
- The design of large chassis obviously improves the stability of the overall crane.
- The central ballast is 20t, and the front and rear counterweights are 10t. The self-assembly can be achieved.

## Operation equipment

### 1) Boom

- Main chord is made of high-strength material, and the boom system employs a space truss structure with uniform section in the middle and variable section at both ends.
- The standard boom has a 7m base, a 10m tip, a 3m intermediate section, four 6m intermediate sections and three 12m intermediate sections.
- The length of the boom is variable between base boom (17m) and the maximum length (80m), which increases progressively by 3m.
- The boom extension is installed on boom tip.

### 2) Fixed jib

- Main chord is made of high-strength material. The boom system employs a space truss structure with uniform section in the middle and variable section at both ends.
- The fixed jib has a 5m base, a 5m tip, a 3m intermediate section, and three 6m intermediate sections.
- The lengths of the fixed jib are 13m, 16m, 19m, 22m, 25m, 28m and 31m.
- It can be installed on the boom with length between 17m and 71m.

### 3) Hook block

- 13.5T ball hook
- 35T lifting hook
- 80T lifting hook
- 130T lifting hook

## Safety device

### 1) Load moment limiter

- The load moment limiter is a matched safety protection system specially designed for SANY SCC series boom crawler crane, in which the performance structure parameters, such as bearing curve, boom weight, center of gravity and other geometrical parameters, of SANY crawler cranes of all series are stored directly. A specific optimization model is employed for the moment calculation, which integrates the technology accumulation of SANY in the crawler crane field for years, has the customized advantage, gives play to the utilization efficiency of the crane to the greatest extent while ensuring the lifting safety and avoids technology disconnection and difficult after-sales service due to the separation of the crane manufacturer from load moment limiter manufacturer in the past, thus achieving the improvement of the quality of the overall crane.
- As the independent safety control system completely controlled by computer, the load moment limiter can detect the lifting weight, operating radius and boom angle of the crane automatically and compare them with the rated load capacity, actual load, actual operating radius and actual boom angle. It can intelligently determine and stop the action of the crane in dangerous direction during normal operation, and has the function of black box to record the overload lifting information.
- It mainly consists of display, controller, angle sensor and force sensor.

### 2) Three-colored load warning lamp

- It reflects the load safety condition of the lifting device, corresponding to the status display of the load progress bar on the display of the load moment limiter.

### 3) Over-hoist limit switch of boom and jib hooks

- When the lifting hook hoists to the upper height limit, the warning information will be generated, and the hoisting action of the lifting hook will be stopped at the same time.

### 4) Over roll-out limit switch of boom and jib hooks

- When the wire rope rolls out to the last three turns, the warning information will be generated, and the electrical control system automatically stops roll-out action of the winch.

### 5) Installation/operating mode changeover switch

- The over-hoist limit switch, crane boom limit device, load moment limiter, etc. don't function in the installation mode for the convenient installation of the crane.
- All safety limit devices function in the operating mode.

### 6) Crane boom limit detecting device

- Under different working conditions, it detects the limit switch and angle signal of the boom system of load moment limiter system to control the boom or jib of the crane to operate in a safe angle.

### 7) Crane boom back-stop device

- The boom employs the oil cylinder back-stop structure to prevent the back-stop of the boom.
- The mechanical back-stop device will prevent back-stop when the fixed jib to boom angle is too small.

### 8) Winch mechanism brake

- Each winch brake employs spring-load normally closed disc brake with great braking force, no maintenance, safety and reliability and long service life.

### 9) Closed circuit monitoring system

- It employs high-definition camera, and the operator in the cab can monitor the real-time status of the luffing drum, lifting winch drum and tail.



**10) Fault self-diagnosis system**

It can generate fault alarm information automatically, check the live operating state of the electrical line and help to remove electrical fault rapidly.

**11) Navigation mark light**

It is installed on the top of the boom system, which allows the boom system to give prompt at high altitude, and the boom is not required to be lowered at night.

**12) Anemometer**

It is installed on the top of the boom system to monitor the wind speed in real time and transmits the data to the cab to be displayed on the monitor.

**13) Gradiometer**

The bubble gradiometer is used as the check base, and the electronic gradiometer as the real-time high precision display to display the inclination angle of the crane and prompt the safe operation ground environment of the crane.

**14) Unhooking prevention device for hook block**

Each lifting hook is equipped with a baffle to prevent the wire rope from falling off.

**15) Operation alarm**

Sound the horn for alarm to prompt that the crane is to be operated to remind other persons to be careful before operating it.

**16) Travel or slewing prompt**

During traveling or slewing operation, the operation warning light will flash with buzzing.

**17) Functional locking**

When the operator leaves the seat or the functional locking lever isn't in position, the control levers of all other functions will fail, thus effectively avoiding some misoperations.

**18) Automatic reversing travel (optional)**

Regardless of the relative positions of the upperworks and lowerworks, the overall crane will travel forward and backward when pushing the travel pedal forward and pulling the travel pedal backward respectively.

**19) Monitor display**

It is a high-precision true-color display and employs overall crane electric man-machine conversation display terminal. It can display the operating states and real-time parameters of engine system, hydraulic system, electrical system, etc.

# SCC1350E

19	Working condition combination
20	Boom H working condition
24	Fixed jib FJ working condition



## Working condition combination

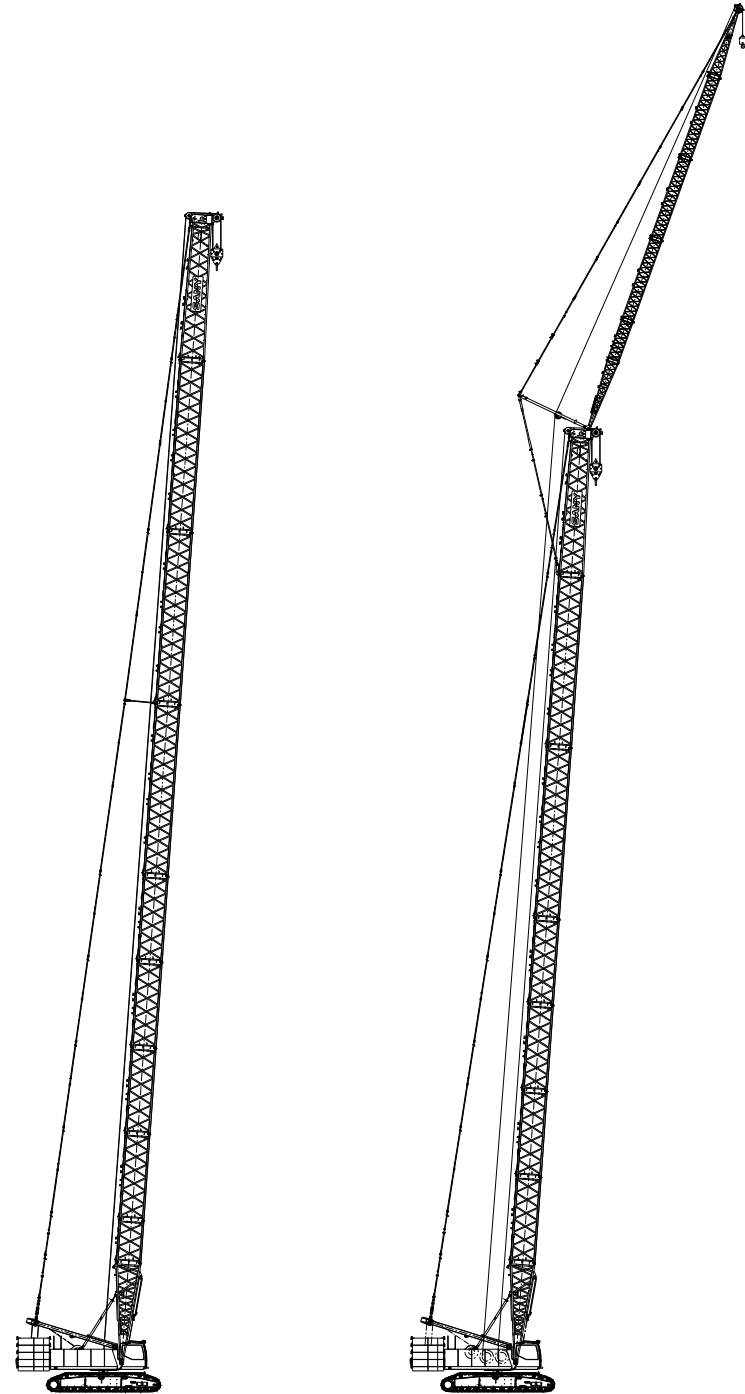

Boom H working condition

Fixed jib FJ working condition

## Boom working condition

### Boom combination

Length (m)	Intermediate section			Mid-point suspension cable
	3 m	6 m	12m	
17	-	-	-	-
20	1	-	-	-
23	-	1	-	-
26	1	1	-	-
29	-	-	1	-
32	1	-	1	-
35	-	1	1	-
38	1	1	1	-
41	-	-	2	-
44	1	-	2	-
47	-	1	2	-
50	1	1	2	-
53	-	-	3	-
56	1	-	3	-
59	-	1	3	-
62	1	1	3	-
65	-	2	3	-
68	1	2	3	1
71	-	3	3	1
74	1	3	3	1
77	-	4	3	1
80	1	4	3	1

Note: Choose any intermediate section for the combination with the same boom length, preferably the longer intermediate section.

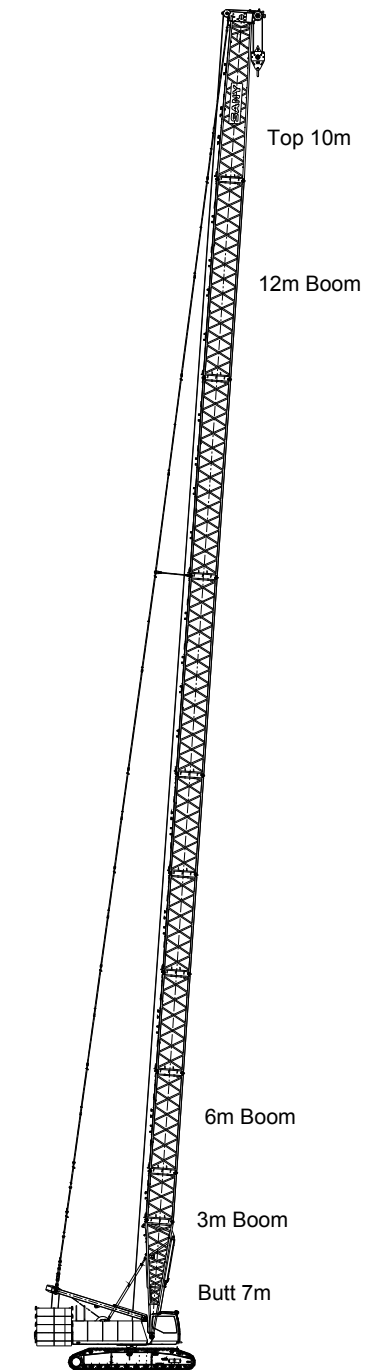

Boom H working  
condition: 17m-80m

# Diagram of operation range of boom working condition

Diagram of operation range of boom (H) working condition

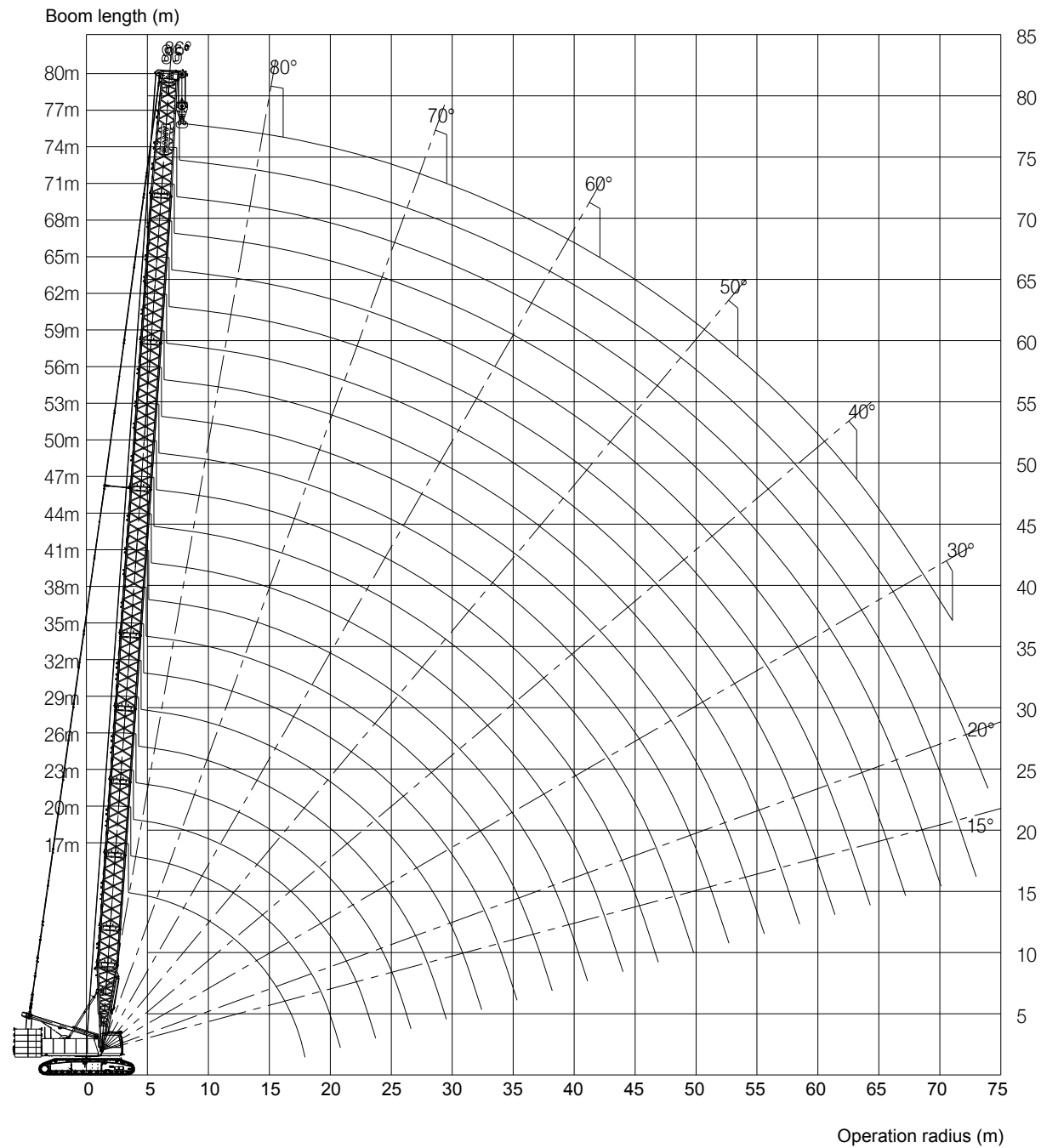

# Load table of boom

Load table of H working condition of SCC1350E crawler crane

Radius (m)	Main hook, boom 17-80m, without boom extension Unit: t											Radius (m)
	Length (m)											
	17	20	23	26	29	32	35	38	41	44	47	
4	140.0	135.0	130.0									4
5	124.0	119.0	118.0	117.0	112.0	106.2	94.6	86.9				5
6	104.0	106.8	102.5	97.8	97.7	97.6	89.0	82.3	74.5	66.2	58.3	6
7	95.4	87.0	88.9	90.8	87.2	83.5	80.0	75.6	68.2	60.5	55.8	7
8	81.0	80.3	79.6	78.8	77.1	75.4	72.0	68.5	63.2	57.8	53.5	8
9	71.4	70.8	70.2	69.6	68.2	66.8	64.3	61.8	57.8	53.8	51.0	9
10	63.8	63.3	62.8	62.2	59.7	57.2	56.7	56.2	53.1	50.0	47.2	10
12	50.7	50.4	50.2	49.9	49.6	49.3	48.0	46.6	45.4	44.1	42.6	12
14	41.2	41.0	40.8	40.6	40.4	40.1	39.9	39.6	38.1	36.5	35.7	14
16	34.6	34.4	34.3	34.0	33.8	33.6	33.4	33.1	32.9	32.6	31.9	16
18		29.5	29.4	29.2	29.0	28.8	28.6	28.3	28.1	27.9	27.7	18
20		25.7	25.6	25.4	25.2	25.0	24.8	24.6	24.4	24.2	24.1	20
22			22.6	22.4	22.3	22.1	21.9	21.7	21.5	21.2	21.1	22
24				20.0	19.8	19.6	19.4	19.2	19.0	18.8	18.7	24
26				17.9	17.8	17.6	17.4	17.2	17.0	16.8	16.7	26
28					16.1	15.9	15.7	15.5	15.3	15.1	15.0	28
30						14.4	14.3	14.1	13.9	13.7	13.6	30
32						13.1	13.0	12.8	12.6	12.4	12.3	32
34							11.9	11.7	11.5	11.3	11.2	34
36								10.7	10.6	10.3	10.2	36
38								9.8	9.7	9.5	9.4	38
40									8.9	8.7	8.6	40
42										8.0	7.9	42
44										7.4	7.3	44
46											6.7	46
48												48
50												50
52												52
54												54
56												56
58												58
60												60
62												62
Counterweight	54+20	54+20	54+20	54+20	54+20	54+20	54+20	54+20	54+20	54+20	54+20	Counterweight
Rate	12	12	11	10	10	9	8	8	7	6	5	Rate

Notes:  
 1. The actual lifting weight is equal to the value that the rated lifting weight in the table subtracts the weight of all the lifting devices such as lifting hook.  
 2. The rated lifting weight in the table is the weight of the non-traveling weight which is lifted slowly and steadily from the hard level ground.

# Load table of boom

## Load table of H working condition of SCC1350E crawler crane

Radius (m)	Main hook, boom 17-80m, without boom extension Unit: t											Radius (m)
	Length (m)											
	50	53	56	59	62	65	68	71	74	77	80	
4												4
5												5
6	53.3	47.5										6
7	50.8	46.5	45.0	38.5	36.9	31.0						7
8	48.8	45.5	42.8	37.3	35.1	30.5	29.5	26.7	23.8	21.5	19.2	8
9	47.8	44.6	41.4	36.2	34.0	29.8	29.1	26.1	23.1	21.0	18.8	9
10	43.8	42.2	40.1	35.8	33.2	28.9	27.9	25.0	22.5	20.4	18.2	10
12	41.1	39.7	38.3	35.1	31.9	28.5	27.0	24.4	22.1	19.9	17.9	12
14	34.9	34.5	34.0	32.6	30.2	27.8	24.8	24.0	21.0	19.2	17.4	14
16	31.1	30.4	29.6	28.6	27.6	26.0	22.5	21.4	20.0	18.2	16.3	16
18	27.4	26.7	26.0	24.6	23.2	22.6	21.0	20.3	18.5	17.0	15.4	18
20	23.8	23.6	23.1	22.6	22.0	21.4	19.2	19.3	17.5	16.0	14.5	20
22	20.9	20.7	20.4	20.2	19.7	19.2	18.2	17.6	16.4	14.3	12.1	22
24	18.5	18.3	18.1	17.9	17.7	17.2	16.7	16.1	15.6	13.6	11.5	24
26	16.5	16.3	16.1	15.9	15.7	15.5	15.1	14.7	14.2	12.6	11.0	26
28	14.8	14.6	14.4	14.2	14.0	13.8	13.6	12.9	12.1	11.3	10.5	28
30	13.4	13.2	12.9	12.8	12.6	12.4	12.2	11.9	11.5	10.8	10.1	30
32	12.1	11.9	11.7	11.6	11.3	11.1	10.9	10.8	10.5	10.1	9.5	32
34	11.0	10.8	10.6	10.5	10.3	10.1	9.8	9.7	9.5	9.2	8.8	34
36	10.0	9.9	9.6	9.5	9.3	9.1	8.9	8.7	8.5	8.2	7.9	36
38	9.2	9.0	8.8	8.7	8.4	8.2	8.0	7.9	7.7	7.4	7.0	38
40	8.4	8.2	8.0	7.9	7.7	7.5	7.3	7.1	6.9	6.6	6.3	40
42	7.7	7.5	7.3	7.2	7.0	6.8	6.6	6.4	6.2	5.9	5.6	42
44	7.1	6.9	6.7	6.6	6.4	6.2	5.9	5.8	5.6	5.3	5.0	44
46	6.5	6.3	6.1	6.0	5.8	5.6	5.4	5.2	5.0	4.8	4.5	46
48	6.0	5.8	5.6	5.5	5.3	5.1	4.8	4.7	4.5	4.3	4.0	48
50		5.3	5.1	5.0	4.8	4.6	4.4	4.2	4.0	3.8	3.5	50
52		4.9	4.7	4.6	4.3	4.2	3.9	3.8	3.6	3.4	3.1	52
54			4.3	4.1	3.9	3.7	3.5	3.4	3.2	3.0	2.7	54
56				3.8	3.6	3.4	3.2	3.0	2.8	2.6	2.3	56
58					3.4	3.2	3.0	2.8	2.7	2.5	2.3	58
60						2.9	2.7	2.5	2.3	2.1		60
62							2.3	2.2	2.0			62
Counterweight	54+20	54+20	54+20	54+20	54+20	54+20	54+20	54+20	54+20	54+20	54+20	Counterweight
Rate	5	4	4	4	4	3	3	3	2	2	2	Rate

Notes:  
 1. The actual lifting weight is equal to the value that the rated lifting weight in the table subtracts the weight of all the lifting devices such as lifting hook.  
 2. The rated lifting weight in the table is the weight of the non-traveling weight which is lifted slowly and steadily from the hard level ground.

# Fixed jib FJw or king condition

## Fixed jib combination

Jib length (m)	Intermediate section		Boom length (m)	Boom to jib angle
	3 m	6 m		
13	1	-	17-71	15°, 30°
16	-	1	17-71	15°, 30°
19	1	1	17-68	15°, 30°
22	-	2	17-68	15°, 30°
25	1	2	17-68	15°, 30°
28	-	3	17-65	15°, 30°
31	1	3	17-65	15°, 30°

Note:  
 The boom less than 35m has the interval of the boom length of 6m;  
 The boom greater than 35m has the interval of the boom length of 3m.

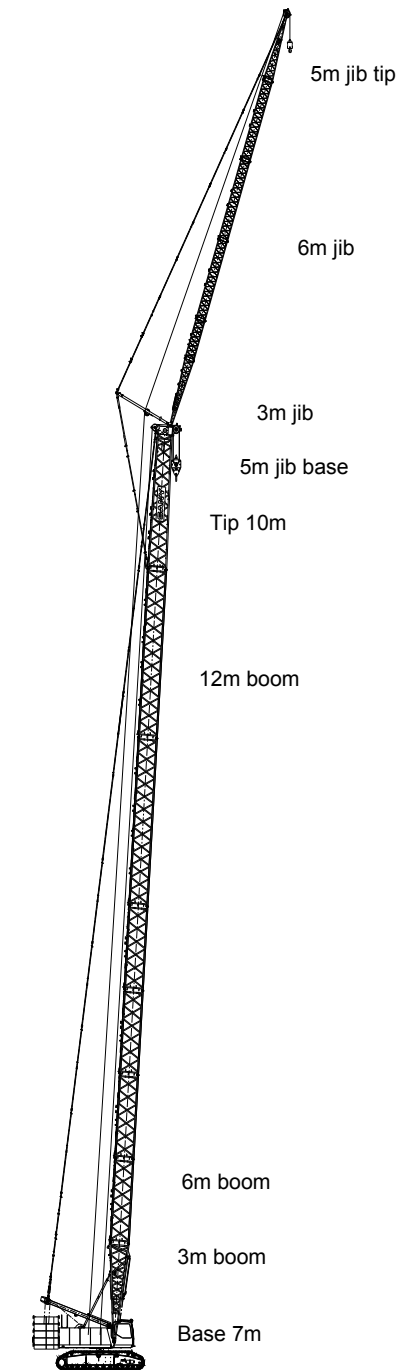

Fixed jib FJ working condition:  
 (17m-71m) + (13m-31m)

## Diagram of operation range of fixed jib

Diagram of operation range of fixed jib (FJ) working condition

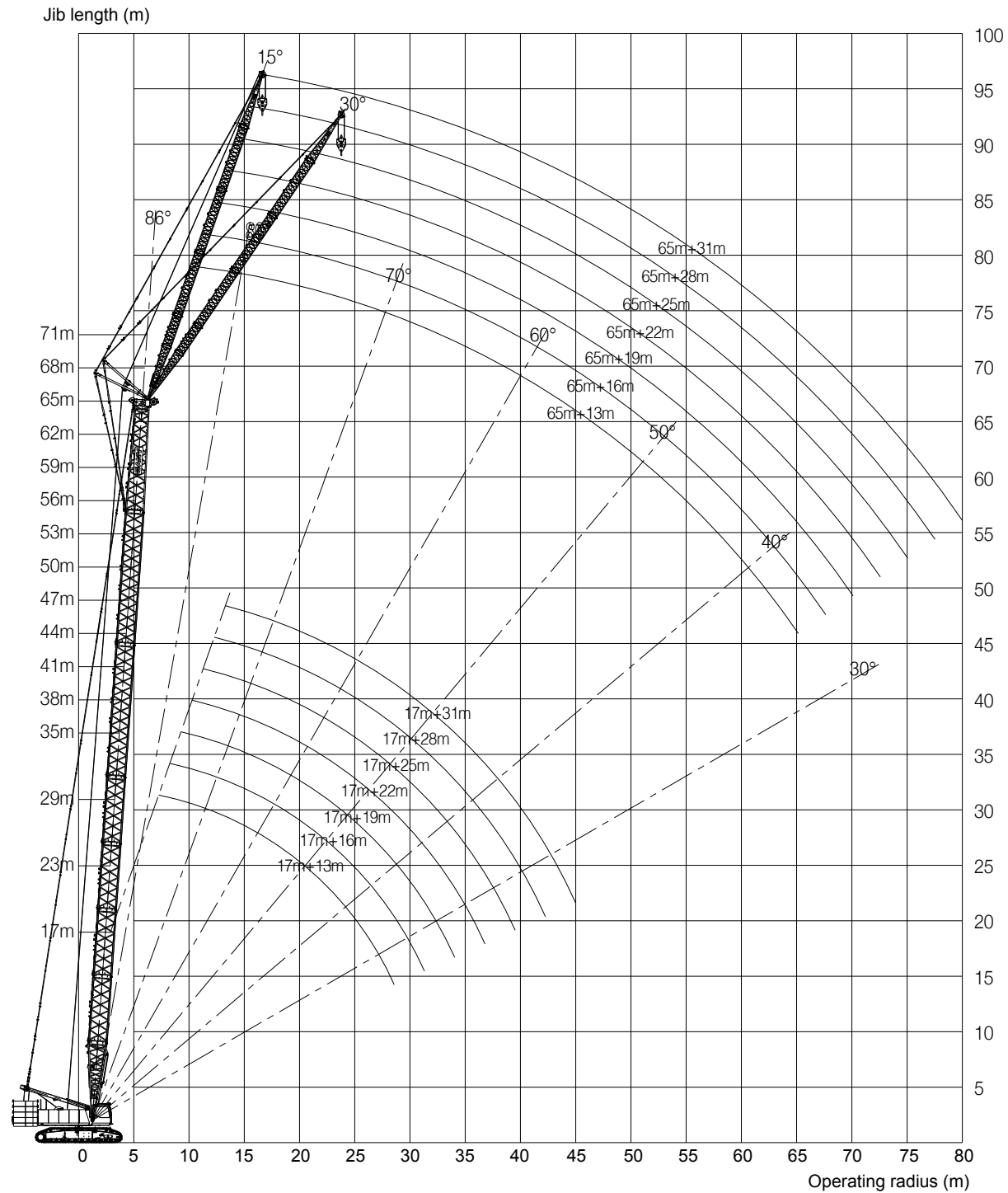

## Load table of fixed jib

Load table of fixed jib FJ working condition of SCC1350E crawler crane

Radius (m)	Auxiliary hook, boom 17-71m, jib 13m, and boom to jib angle 15° Unit: t								Radius (m)	
	Length (m)	17	23	29	35	38	41	44		47
7	30.0									7
8	30.0	29.0								8
9	27.8	25.5	23.2	23.0	22.7	22.2				9
10	26.6	25.2	23.3	23.1	22.8	22.3	21.8	21.3		10
12	25.6	25.0	23.5	23.4	23.0	22.5	22.0	21.4		12
14	25.6	25.2	23.6	23.5	23.1	22.6	22.1	21.5		14
16	25.4	25.3	23.7	23.7	23.3	22.8	22.2	21.6		16
18	24.5	25.1	23.9	23.9	23.4	22.8	22.4	21.8		18
20	23.7	24.6	24.1	23.9	23.5	23.0	22.6	21.9		20
22	22.3	23.2	22.8	22.4	22.2	22.0	21.8	21.6		22
24	20.9	20.7	20.3	19.9	19.7	19.5	19.3	19.2		24
26	19.1	18.7	18.3	17.9	17.7	17.5	17.3	17.2		26
28	17.3	17.0	16.6	16.2	16.0	15.8	15.6	15.5		28
30		15.5	15.1	14.7	14.5	14.3	14.1	14.0		30
32		14.2	13.8	13.4	13.2	13.0	12.8	12.7		32
34		13.0	12.7	12.3	12.1	11.9	11.7	11.6		34
36			11.7	11.3	11.1	10.9	10.7	10.6		36
38			10.8	10.4	10.2	10.0	9.8	9.7		38
40				9.6	9.4	9.3	9.0	8.9		40
42				8.9	8.7	8.5	8.3	8.2		42
44				8.3	8.1	7.9	7.7	7.6		44
46					7.5	7.3	7.1	7.0		46
48						6.8	6.6	6.4		48
50							6.1	5.9		50
52							5.6	5.5		52
54								5.1		54
56										56
58										58
60										60
62										62
64										64
66										66
Counterweight	54+20	54+20	54+20	54+20	54+20	54+20	54+20	54+20	54+20	Counterweight
Rate	3	3	2	2	2	2	2	2	2	Rate

Notes:

1. The actual lifting weight is equal to the value that the rated lifting weight in the table subtracts the weight of all the lifting devices such as lifting hook
2. The rated lifting weight in the table is the weight of the non-traveling weight which is lifted slowly and steadily from the hard level ground.



## Load Chart of Fixed Jib

Load table of fixed jib FJ working condition of SCC1350E crawler crane

Radius (m)	Auxiliary hook, boom 17-71m, jib 13m, and boom to jib angle 15° Unit: t								Radius (m)
	50	53	56	59	62	65	68	71	
7									7
8									8
9									9
10	20.9	20.2	19.8						10
12	20.9	20.3	19.9	19.3	17.7	16.2	14.8	13.6	12
14	21.0	20.5	19.9	19.3	17.7	16.1	14.7	13.5	14
16	21.2	20.6	20.0	19.2	17.6	16.0	14.6	13.4	16
18	21.3	20.6	20.1	19.2	17.5	15.9	14.6	13.2	18
20	21.5	20.8	20.1	19.1	17.4	15.8	14.4	13.2	20
22	21.4	20.8	20.2	19.1	17.4	15.8	14.4	13.0	22
24	19.0	18.8	18.6	18.4	17.4	15.7	14.2	13.0	24
26	17.0	16.8	16.6	16.4	16.2	15.6	14.2	12.9	26
28	15.2	15.1	14.9	14.7	14.5	14.3	14.0	12.7	28
30	13.8	13.6	13.4	13.2	13.0	12.9	12.7	12.4	30
32	12.5	12.3	12.1	12.0	11.8	11.6	11.4	11.2	32
34	11.4	11.2	11.0	10.8	10.6	10.5	10.3	10.1	34
36	10.4	10.2	10.0	9.9	9.7	9.5	9.3	9.1	36
38	9.5	9.3	9.1	9.0	8.8	8.6	8.4	8.2	38
40	8.7	8.5	8.3	8.2	8.0	7.8	7.6	7.5	40
42	8.0	7.8	7.6	7.5	7.3	7.1	6.9	6.7	42
44	7.4	7.2	7.0	6.8	6.6	6.4	6.2	6.1	44
46	6.8	6.6	6.4	6.3	6.0	5.9	5.7	5.5	46
48	6.2	6.1	5.8	5.7	5.5	5.3	5.1	5.0	48
50	5.7	5.6	5.4	5.2	5.0	4.8	4.6	4.5	50
52	5.3	5.1	4.9	4.8	4.6	4.4	4.2	4.0	52
54	4.9	4.7	4.5	4.3	4.1	4.0	3.8	3.2	54
56	4.5	4.3	4.1	4.0	3.8	3.6	3.4	2.6	56
58		3.9	3.7	3.6	3.4	3.2	2.8		58
60		3.6	3.4	3.3	3.1	2.9	2.2		60
62			3.1	2.9	2.7	2.5			62
64				2.6	2.4	2.2			64
66					2.1				66
Counterweight	54+20	54+20	54+20	54+20	54+20	54+20	54+20	54+20	Counterweight
Rate	2	2	2	2	2	2	2	2	Rate

Notes:

1. The actual lifting weight is equal to the value that the rated lifting weight in the table subtracts the weight of all the lifting devices such as lifting hook
2. The rated lifting weight in the table is the weight of the non-traveling weight which is lifted slowly and steadily from the hard level ground.

## Load Chart of Fixed Jib

Load table of fixed jib FJ working condition of SCC1350E crawler crane

Radius (m)	Auxiliary hook, boom 17-71m, jib 16m, and boom to jib angle 15° Unit: t								Radius (m)
	17	23	29	35	38	41	44	47	
8	24.2								8
9	23.1	22.6	20.9						9
10	23.1	22.6	20.9	21.3	21.0	20.4			10
12	23.3	22.8	21.1	21.5	21.0	20.7	20.2	19.7	12
14	22.9	23.0	21.3	21.6	21.2	20.7	20.3	19.8	14
16	21.9	22.4	21.4	21.6	21.2	20.8	20.4	20.0	16
18	21.2	21.7	21.6	21.8	21.4	20.9	20.5	20.0	18
20	20.5	21.1	21.5	21.6	21.6	21.1	20.6	20.1	20
22	19.9	20.4	20.9	21.0	21.1	20.9	20.8	20.2	22
24	18.6	19.8	20.3	20.1	19.9	19.8	19.6	19.4	24
26	17.4	18.9	18.5	18.1	17.9	17.7	17.5	17.4	26
28	16.4	17.1	16.8	16.4	16.2	16.0	15.8	15.7	28
30	15.7	15.7	15.3	14.9	14.7	14.5	14.3	14.2	30
32		14.4	14.0	13.6	13.4	13.2	13.0	12.9	32
34		13.2	12.9	12.5	12.3	12.1	11.9	11.8	34
36		12.2	11.9	11.5	11.3	11.1	10.9	10.8	36
38			11.0	10.6	10.4	10.2	10.0	9.9	38
40			10.2	9.8	9.6	9.4	9.2	9.1	40
42			9.5	9.1	8.9	8.7	8.5	8.4	42
44				8.4	8.2	8.1	7.9	7.7	44
46				7.8	7.6	7.5	7.3	7.2	46
48					7.1	6.9	6.7	6.6	48
50					6.6	6.4	6.2	6.1	50
52						6.0	5.8	5.7	52
54							5.3	5.2	54
56								4.8	56
58									58
60									60
62									62
64									64
66									66
68									68
Counterweight	54+20	54+20	54+20	54+20	54+20	54+20	54+20	54+20	Counterweight
Rate	3	2	2	2	2	2	2	2	Rate

Notes:

1. The actual lifting weight is equal to the value that the rated lifting weight in the table subtracts the weight of all the lifting devices such as lifting hook
2. The rated lifting weight in the table is the weight of the non-traveling weight which is lifted slowly and steadily from the hard level ground.

## Load Chart of Fixed Jib

Load table of fixed jib FJ working condition of SCC1350E crawler crane

Radius (m)	Auxiliary hook, boom 17-71m, jib 16m, and boom to jib angle 15° Unit: t								Radius (m)
	50	53	56	59	62	65	68	71	
8									8
9									9
10									10
12	19.3	18.7	17.7	16.4	15.2	14.1	12.9	11.9	12
14	19.3	18.8	17.6	16.5	15.2	14.0	12.9	11.9	14
16	19.4	19.0	17.7	16.4	15.2	14.0	12.7	11.8	16
18	19.5	19.0	17.7	16.4	15.1	13.8	12.7	11.6	18
20	19.7	19.1	17.7	16.4	15.1	13.8	12.7	11.6	20
22	19.8	19.2	17.8	16.4	15.0	13.8	12.6	11.5	22
24	19.2	19.0	17.8	16.3	15.0	13.7	12.6	11.5	24
26	17.2	17.0	16.8	16.4	15.1	13.6	12.5	11.4	26
28	15.5	15.3	15.1	14.9	14.8	13.7	12.4	11.3	28
30	14.0	13.8	13.6	13.5	13.3	13.1	12.3	11.2	30
32	12.7	12.5	12.3	12.2	12.0	11.8	11.6	11.1	32
34	11.6	11.4	11.2	11.1	10.9	10.7	10.5	10.3	34
36	10.6	10.4	10.2	10.1	9.9	9.7	9.5	9.3	36
38	9.7	9.5	9.3	9.2	9.0	8.8	8.6	8.5	38
40	8.9	8.7	8.5	8.4	8.2	8.0	7.8	7.7	40
42	8.2	8.0	7.8	7.7	7.5	7.3	7.1	6.9	42
44	7.5	7.4	7.2	7.0	6.8	6.6	6.4	6.3	44
46	6.9	6.8	6.6	6.4	6.2	6.0	5.8	5.7	46
48	6.4	6.2	6.0	5.9	5.7	5.5	5.3	5.2	48
50	5.9	5.7	5.5	5.4	5.2	5.0	4.8	4.7	50
52	5.5	5.3	5.1	4.9	4.7	4.6	4.4	4.2	52
54	5.0	4.8	4.6	4.5	4.3	4.1	3.9	3.8	54
56	4.6	4.5	4.3	4.1	3.9	3.7	3.5	3.4	56
58	4.3	4.1	3.9	3.8	3.6	3.4	3.2	2.8	58
60	3.9	3.7	3.5	3.4	3.2	3.0	2.8	2.0	60
62		3.4	3.2	3.1	2.9	2.7	2.5		62
64			2.9	2.8	2.6	2.4			64
66				2.5	2.3	2.1			66
68					2.2	2.0			68
Counterweight	54+20	54+20	54+20	54+20	54+20	54+20	54+20	54+20	Counterweight
Rate	2	2	2	2	2	2	2	1	Rate

Notes:

1. The actual lifting weight is equal to the value that the rated lifting weight in the table subtracts the weight of all the lifting devices such as lifting hook
2. The rated lifting weight in the table is the weight of the non-traveling weight which is lifted slowly and steadily from the hard level ground.

## Load Chart of Fixed Jib

Load table of fixed jib FJ working condition of SCC1350E crawler crane

Radius (m)	Auxiliary hook, boom 17-68m, jib 19m, and boom to jib angle 15° Unit: t								Radius (m)
	17	23	29	35	38	41	44	47	
9	21.6								9
10	20.9	20.7	19.3						10
12	20.0	20.1	19.5	19.8	19.6	19.3	18.5	17.7	12
14	19.2	19.4	19.4	19.3	19.1	19.0	18.8	17.7	14
16	18.4	18.8	18.9	18.8	18.7	18.7	18.5	17.9	16
18	17.8	18.2	18.4	18.4	18.3	18.3	18.1	18.0	18
20	17.2	17.7	17.9	18.0	17.9	17.9	17.9	17.7	20
22	16.6	17.1	17.4	17.6	17.6	17.6	17.5	17.4	22
24	16.0	16.6	17.0	17.2	17.3	17.2	17.2	17.1	24
26	15.6	16.2	16.6	16.8	16.9	16.9	16.9	16.8	26
28	14.9	15.8	16.2	16.5	16.3	16.1	15.9	15.8	28
30	14.1	15.4	15.4	15.0	14.8	14.7	14.5	14.3	30
32	13.4	14.5	14.1	13.7	13.5	13.4	13.2	13.0	32
34	12.7	13.4	13.0	12.6	12.4	12.2	12.0	11.9	34
36		12.4	12.0	11.6	11.4	11.2	11.0	10.9	36
38		11.5	11.1	10.7	10.5	10.4	10.2	10.0	38
40			10.3	9.9	9.7	9.6	9.4	9.2	40
42			9.6	9.2	9.0	8.8	8.6	8.5	42
44			8.9	8.6	8.4	8.2	8.0	7.9	44
46				8.0	7.8	7.6	7.4	7.3	46
48				7.4	7.2	7.1	6.9	6.7	48
50				6.9	6.7	6.6	6.4	6.2	50
52					6.3	6.1	5.9	5.8	52
54						5.7	5.5	5.4	54
56							5.1	5.0	56
58							4.7	4.6	58
60								4.2	60
62									62
64									64
66									66
68									68
70									70
Counterweight	54+20	54+20	54+20	54+20	54+20	54+20	54+20	54+20	Counterweight
Rate	2	2	2	2	2	2	2	2	Rate

Notes:

1. The actual lifting weight is equal to the value that the rated lifting weight in the table subtracts the weight of all the lifting devices such as lifting hook
2. The rated lifting weight in the table is the weight of the non-traveling weight which is lifted slowly and steadily from the hard level ground.

## Load Chart of Fixed Jib

Load table of fixed jib FJ working condition of SCC1350E crawler crane

Length (m)		Auxiliary hook, boom 17-68m, jib 19m, and boom to jib angle 15° Unit: t						Length (m)	
Radius (m)	50	53	56	59	62	65	68	Radius (m)	
9								9	
10								10	
12	16.7	15.7	14.8					12	
14	16.7	15.8	14.7	13.9	12.9	11.9	11.1	14	
16	16.8	15.9	14.8	13.9	12.9	12.0	11.1	16	
18	16.9	15.9	14.8	13.9	13.0	11.9	11.0	18	
20	17.0	16.0	14.9	14.0	12.9	11.9	11.0	20	
22	17.1	16.1	14.9	14.0	12.9	11.9	10.9	22	
24	17.0	16.1	15.0	14.0	12.9	11.9	10.9	24	
26	16.7	16.2	15.1	13.9	12.9	11.9	10.8	26	
28	15.6	15.4	15.1	14.0	12.9	11.9	10.8	28	
30	14.1	14.0	13.8	13.6	12.9	11.8	10.8	30	
32	12.8	12.7	12.5	12.3	12.2	11.8	10.8	32	
34	11.7	11.5	11.3	11.2	11.0	10.8	10.7	34	
36	10.7	10.5	10.4	10.2	10.0	9.8	9.7	36	
38	9.8	9.7	9.5	9.3	9.1	9.0	8.8	38	
40	9.0	8.9	8.7	8.5	8.3	8.2	8.0	40	
42	8.3	8.1	7.9	7.8	7.6	7.4	7.2	42	
44	7.7	7.5	7.3	7.2	7.0	6.8	6.6	44	
46	7.1	6.9	6.7	6.6	6.4	6.2	6.0	46	
48	6.5	6.4	6.2	6.0	5.8	5.6	5.4	48	
50	6.0	5.9	5.7	5.5	5.3	5.1	5.0	50	
52	5.6	5.4	5.2	5.1	4.9	4.7	4.5	52	
54	5.2	5.0	4.8	4.6	4.4	4.3	4.1	54	
56	4.8	4.6	4.4	4.3	4.1	3.9	3.7	56	
58	4.4	4.2	4.0	3.9	3.7	3.5	3.3	58	
60	4.0	3.9	3.7	3.5	3.3	3.2	3.0	60	
62	3.7	3.5	3.3	3.2	3.0	2.8	2.6	62	
64		3.2	3.0	2.9	2.7	2.5	2.3	64	
66			2.8	2.6	2.4	2.2	2.0	66	
68			2.5	2.4	2.2			68	
70				2.1				70	
Counterweight	54+20	54+20	54+20	54+20	54+20	54+20	54+20	Counterweight	
Rate	2	2	2	2	2	1	1	Rate	

Notes:  
 1. The actual lifting weight is equal to the value that the rated lifting weight in the table subtracts the weight of all the lifting devices such as lifting hook  
 2. The rated lifting weight in the table is the weight of the non-traveling weight which is lifted slowly and steadily from the hard level ground.

## Load Chart of Fixed Jib

Load table of fixed jib FJ working condition of SCC1350E crawler crane

Length (m)		Auxiliary hook, boom 17-68m, jib 22m, and boom to jib angle 15° Unit: t						Length (m)	
Radius (m)	17	23	29	35	38	41	44	47	Radius (m)
11	17.2	18.1	17.7						11
12	16.9	17.8	17.7	16.8	16.1	15.5	15.0		12
14	16.2	17.3	17.4	16.9	16.3	15.7	15.1	14.4	14
16	15.6	16.6	16.8	16.6	16.5	15.9	15.1	14.6	16
18	15.0	16.1	16.4	16.2	16.2	16.0	15.2	14.6	18
20	14.4	15.7	15.9	15.8	15.8	15.7	15.4	14.7	20
22	13.9	15.2	15.5	15.4	15.4	15.4	15.4	14.8	22
24	13.4	14.8	15.1	15.0	15.0	15.0	15.0	14.9	24
26	12.9	14.4	14.7	14.8	14.8	14.8	14.7	14.7	26
28	12.5	13.9	14.4	14.5	14.5	14.6	14.5	14.5	28
30	12.1	13.6	14.0	14.1	14.3	14.2	14.2	14.1	30
32	11.7	13.0	13.7	13.8	13.7	13.5	13.3	13.2	32
34	11.1	12.4	13.1	12.7	12.6	12.4	12.2	12.1	34
36	10.6	11.8	12.1	11.8	11.6	11.4	11.2	11.1	36
38		11.4	11.2	10.9	10.7	10.5	10.3	10.2	38
40		10.8	10.4	10.1	9.9	9.7	9.5	9.4	40
42		10.1	9.7	9.4	9.2	9.0	8.8	8.7	42
44			9.1	8.7	8.5	8.3	8.1	8.0	44
46			8.5	8.1	7.9	7.7	7.5	7.4	46
48			7.9	7.6	7.4	7.2	7.0	6.9	48
50				7.1	6.9	6.7	6.5	6.4	50
52				6.6	6.4	6.2	6.0	5.9	52
54					6.0	5.8	5.6	5.5	54
56						5.4	5.2	5.1	56
58						5.0	4.8	4.7	58
60							4.5	4.4	60
62								4.0	62
64									64
66									66
68									68
70									70
Counterweight	54+20	54+20	54+20	54+20	54+20	54+20	54+20	54+20	Counterweight
Rate	2	2	2	2	2	2	2	2	Rate

Notes:  
 1. The actual lifting weight is equal to the value that the rated lifting weight in the table subtracts the weight of all the lifting devices such as lifting hook  
 2. The rated lifting weight in the table is the weight of the non-traveling weight which is lifted slowly and steadily from the hard level ground.

## Load Chart of Fixed Jib

Load table of fixed jib FJ working condition of SCC1350E crawler crane

Radius (m)	Auxiliary hook, boom 17-68m, jib 22m, and boom to jib angle 15° Unit: t							Radius (m)
	50	53	56	59	62	65	68	
11								11
12								12
14	13.7	13.1	12.3	11.7	10.9	10.2	9.5	14
16	13.8	13.1	12.3	11.7	10.9	10.2	9.4	16
18	13.9	13.2	12.4	11.7	11.0	10.2	9.5	18
20	14.0	13.3	12.4	11.8	11.0	10.2	9.4	20
22	14.0	13.3	12.5	11.8	11.0	10.2	9.4	22
24	14.1	13.4	12.6	11.8	11.0	10.2	9.4	24
26	14.2	13.4	12.6	11.8	11.0	10.2	9.4	26
28	14.3	13.5	12.6	11.9	11.0	10.2	9.3	28
30	14.1	13.6	12.7	11.9	11.1	10.2	9.3	30
32	13.0	12.8	12.7	11.9	11.0	10.1	9.4	32
34	11.9	11.7	11.5	11.4	11.1	10.2	9.3	34
36	10.9	10.7	10.5	10.4	10.2	10.0	9.3	36
38	10.0	9.8	9.6	9.5	9.3	9.1	8.9	38
40	9.2	9.0	8.8	8.7	8.5	8.3	8.1	40
42	8.5	8.3	8.1	8.0	7.8	7.6	7.4	42
44	7.8	7.6	7.5	7.3	7.1	6.9	6.8	44
46	7.2	7.0	6.9	6.7	6.5	6.4	6.2	46
48	6.7	6.5	6.3	6.2	6.0	5.8	5.6	48
50	6.2	6.0	5.8	5.7	5.5	5.3	5.1	50
52	5.7	5.5	5.3	5.2	5.0	4.8	4.6	52
54	5.3	5.1	4.9	4.8	4.6	4.4	4.2	54
56	4.9	4.7	4.5	4.4	4.2	4.0	3.8	56
58	4.5	4.4	4.2	4.0	3.8	3.6	3.5	58
60	4.2	4.0	3.8	3.7	3.5	3.3	3.1	60
62	3.9	3.7	3.5	3.4	3.2	3.0	2.8	62
64	3.5	3.4	3.2	3.1	2.9	2.7	2.5	64
66	3.3	3.1	2.9	2.8	2.6	2.4	2.2	66
68		2.8	2.6	2.5	2.3	2.1		68
70			2.4	2.2	2.0			70
Counterweight	54+20	54+20	54+20	54+20	54+20	54+20	54+20	Counterweight
Rate	2	2	2	1	1	1	1	Rate

Notes:

1. The actual lifting weight is equal to the value that the rated lifting weight in the table subtracts the weight of all the lifting devices such as lifting hook
2. The rated lifting weight in the table is the weight of the non-traveling weight which is lifted slowly and steadily from the hard level ground.

## Load Chart of Fixed Jib

Load table of fixed jib FJ working condition of SCC1350E crawler crane

Radius (m)	Auxiliary hook, boom 17-68m, jib 25m, and boom to jib angle 15° Unit: t							Radius (m)	
	17	23	29	35	38	41	44		47
12	13.9	13.9	13.8						12
14	13.8	14.0	13.8	13.2	12.8	12.5	12.0	11.6	14
16	13.3	14.1	14.0	13.4	13.0	12.6	12.2	11.8	16
18	12.8	13.9	14.0	13.4	13.0	12.7	12.3	11.8	18
20	12.2	13.5	13.6	13.5	13.1	12.8	12.3	11.9	20
22	11.7	13.1	13.3	13.3	13.3	12.9	12.4	12.0	22
24	11.3	12.8	12.9	13.0	13.0	13.0	12.5	12.0	24
26	10.9	12.3	12.6	12.7	12.8	12.8	12.5	12.1	26
28	10.5	11.9	12.3	12.5	12.5	12.5	12.5	12.2	28
30	10.2	11.5	11.9	12.2	12.2	12.3	12.3	12.2	30
32	9.8	11.1	11.6	11.8	11.9	12.1	12.0	12.0	32
34	9.6	10.7	11.2	11.5	11.7	11.8	11.8	11.8	34
36	9.3	10.4	10.8	11.2	11.4	11.5	11.3	11.2	36
38	9.0	10.1	10.5	10.9	10.8	10.6	10.4	10.3	38
40	8.7	9.8	10.2	10.2	10.0	9.8	9.6	9.5	40
42		9.6	9.8	9.4	9.3	9.1	8.9	8.8	42
44		9.3	9.1	8.8	8.6	8.4	8.2	8.1	44
46			8.5	8.2	8.0	7.8	7.6	7.5	46
48			8.0	7.7	7.5	7.3	7.1	7.0	48
50			7.5	7.2	7.0	6.8	6.6	6.5	50
52				6.7	6.5	6.3	6.1	6.0	52
54				6.3	6.1	5.9	5.7	5.6	54
56				5.8	5.7	5.5	5.3	5.2	56
58					5.3	5.1	4.9	4.8	58
60						4.8	4.6	4.5	60
62							4.3	4.1	62
64								3.8	64
66								3.5	66
68									68
70									70
72									72
Counterweight	54+20	54+20	54+20	54+20	54+20	54+20	54+20	54+20	Counterweight
Rate	2	2	2	2	2	2	2	2	Rate

Notes:

1. The actual lifting weight is equal to the value that the rated lifting weight in the table subtracts the weight of all the lifting devices such as lifting hook
2. The rated lifting weight in the table is the weight of the non-traveling weight which is lifted slowly and steadily from the hard level ground.

## Load Chart of Fixed Jib

Load table of fixed jib FJ working condition of SCC1350E crawler crane

Radius (m)	Auxiliary hook, boom 17-68m, jib 25m, and boom to jib angle 15° Unit: t							Radius (m)
	Length (m)							
	50	53	56	59	62	65	68	
12								12
14	11.1	10.7	10.2					14
16	11.2	10.8	10.2	9.7	9.2	8.6	8.0	16
18	11.3	10.8	10.3	9.8	9.2	8.6	8.1	18
20	11.4	10.9	10.3	9.8	9.3	8.6	8.0	20
22	11.5	11.0	10.4	9.8	9.3	8.6	8.0	22
24	11.5	11.0	10.5	9.9	9.3	8.7	8.1	24
26	11.6	11.1	10.5	9.9	9.3	8.7	8.1	26
28	11.6	11.1	10.5	9.9	9.3	8.6	8.1	28
30	11.7	11.2	10.6	10.0	9.3	8.6	8.0	30
32	11.8	11.2	10.6	10.0	9.3	8.7	8.0	32
34	11.7	11.3	10.6	10.1	9.4	8.7	8.0	34
36	11.0	10.8	10.6	10.1	9.4	8.7	8.0	36
38	10.1	9.9	9.8	9.6	9.4	8.7	8.0	38
40	9.3	9.1	8.9	8.8	8.6	8.5	8.0	40
42	8.6	8.4	8.2	8.1	7.9	7.7	7.5	42
44	7.9	7.8	7.6	7.4	7.2	7.1	6.9	44
46	7.3	7.2	7.0	6.8	6.6	6.5	6.3	46
48	6.8	6.6	6.4	6.3	6.1	5.9	5.7	48
50	6.3	6.1	5.9	5.8	5.6	5.4	5.2	50
52	5.8	5.7	5.5	5.3	5.1	5.0	4.8	52
54	5.4	5.2	5.0	4.9	4.7	4.5	4.3	54
56	5.0	4.8	4.6	4.5	4.3	4.1	3.9	56
58	4.6	4.5	4.3	4.1	3.9	3.8	3.6	58
60	4.3	4.1	3.9	3.8	3.6	3.4	3.2	60
62	4.0	3.8	3.6	3.5	3.3	3.1	2.9	62
64	3.7	3.5	3.3	3.2	3.0	2.8	2.6	64
66	3.4	3.2	3.0	2.9	2.7	2.5	2.3	66
68	3.1	2.9	2.7	2.6	2.4	2.2	2.0	68
70		2.7	2.5	2.3	2.1			70
72			2.2	2.1				72
Counterweight	54+20	54+20	54+20	54+20	54+20	54+20	54+20	Counterweight
Rate	1	1	1	1	1	1	1	Rate

Notes:

1. The actual lifting weight is equal to the value that the rated lifting weight in the table subtracts the weight of all the lifting devices such as lifting hook
2. The rated lifting weight in the table is the weight of the non-traveling weight which is lifted slowly and steadily from the hard level ground.

## Load Chart of Fixed Jib

Load table of fixed jib FJ working condition of SCC1350E crawler crane

Radius (m)	Auxiliary hook, boom 17-65m, fixed jib 28m, and boom to jib angle 15° Unit: t							Radius (m)
	Length (m)							
	17	23	29	35	38	41	44	
14	10.7	10.9	10.8	10.4	10.2	10.0	9.7	14
16	10.7	11.0	10.9	10.5	10.3	10.1	9.8	16
18	10.7	11.0	11.0	10.5	10.4	10.1	9.8	18
20	10.5	10.9	11.0	10.6	10.4	10.2	9.9	20
22	10.0	10.9	11.0	10.6	10.4	10.3	10.0	22
24	9.6	10.6	10.8	10.6	10.5	10.3	10.0	24
26	9.2	10.1	10.4	10.3	10.3	10.3	10.0	26
28	8.8	9.7	10.0	10.1	10.1	10.1	10.0	28
30	8.4	9.3	9.7	9.8	9.8	9.8	9.8	30
32	8.0	8.9	9.4	9.6	9.6	9.6	9.6	32
34	7.6	8.6	9.0	9.3	9.4	9.4	9.4	34
36	7.3	8.3	8.7	9.0	9.2	9.2	9.2	36
38	7.0	8.0	8.4	8.7	8.9	9.0	9.0	38
40	6.8	7.7	8.1	8.5	8.6	8.8	8.8	40
42	6.5	7.4	7.8	8.2	8.4	8.5	8.6	42
44		7.2	7.6	8.0	8.2	8.3	8.3	44
46		7.0	7.4	7.7	7.9	7.9	7.7	46
48		6.9	7.1	7.6	7.6	7.4	7.2	48
50			7.0	7.2	7.1	6.9	6.7	50
52			6.9	6.8	6.6	6.4	6.2	52
54				6.4	6.2	6.0	5.8	54
56				6.0	5.8	5.6	5.4	56
58				5.6	5.4	5.2	5.0	58
60					5.0	4.9	4.7	60
62						4.6	4.4	62
64						4.2	4.1	64
66							3.8	66
68								68
70								70
72								72
74								74
Counterweight (t)	54+20	55+20	55+20	55+20	55+20	55+20	55+20	Counterweight
Rate	1	1	1	1	1	1	1	Rate

Notes:

1. The actual lifting weight is equal to the value that the rated lifting weight in the table subtracts the weight of all the lifting devices such as lifting hook
2. The rated lifting weight in the table is the weight of the non-traveling weight which is lifted slowly and steadily from the hard level ground.



## Load Chart of Fixed Jib

Load table of fixed jib FJ working condition of SCC1350E crawler crane

Radius (m)	Auxiliary hook, boom 17-65m, fixed jib 28m, and boom to jib angle 15° Unit: t							Radius (m)
	47	50	53	56	59	62	65	
14								14
16	9.5	9.1	8.8	8.5	8.1	7.7	7.2	16
18	9.6	9.2	8.9	8.5	8.1	7.7	7.3	18
20	9.6	9.2	8.9	8.5	8.1	7.7	7.3	20
22	9.7	9.3	9.0	8.6	8.2	7.8	7.3	22
24	9.7	9.3	9.0	8.6	8.2	7.8	7.3	24
26	9.7	9.4	9.0	8.6	8.2	7.8	7.3	26
28	9.8	9.5	9.1	8.7	8.3	7.8	7.3	28
30	9.8	9.5	9.1	8.7	8.3	7.8	7.3	30
32	9.6	9.5	9.1	8.7	8.3	7.9	7.3	32
34	9.4	9.3	9.2	8.8	8.3	7.9	7.3	34
36	9.2	9.2	9.1	8.8	8.4	7.9	7.3	36
38	9.0	9.0	8.9	8.8	8.4	7.9	7.4	38
40	8.8	8.8	8.8	8.7	8.4	7.9	7.3	40
42	8.6	8.6	8.5	8.3	8.2	7.9	7.3	42
44	8.2	8.0	7.9	7.7	7.6	7.4	7.2	44
46	7.6	7.4	7.3	7.1	7.0	6.8	6.6	46
48	7.1	6.9	6.7	6.5	6.4	6.2	6.1	48
50	6.6	6.4	6.2	6.0	5.9	5.7	5.6	50
52	6.1	5.9	5.8	5.6	5.4	5.3	5.1	52
54	5.7	5.5	5.3	5.1	5.0	4.8	4.7	54
56	5.3	5.1	4.9	4.7	4.6	4.4	4.3	56
58	4.9	4.7	4.6	4.4	4.2	4.1	3.9	58
60	4.6	4.4	4.2	4.0	3.9	3.7	3.5	60
62	4.3	4.1	3.9	3.7	3.6	3.4	3.2	62
64	3.9	3.8	3.6	3.4	3.3	3.1	2.9	64
66	3.7	3.5	3.3	3.1	3.0	2.8	2.6	66
68	3.4	3.2	3.0	2.8	2.7	2.5	2.3	68
70		2.9	2.8	2.6	2.5	2.3	2.1	70
72		2.7	2.5	2.3	2.2	2.0		72
74			2.3	2.1				74
Counterweight	55+20	55+20	55+20	55+20	55+20	55+20	55+20	Counterweight
Rate	1	1	1	1	1	1	1	Rate

Notes:

1. The actual lifting weight is equal to the value that the rated lifting weight in the table subtracts the weight of all the lifting devices such as lifting hook
2. The rated lifting weight in the table is the weight of the non-traveling weight which is lifted slowly and steadily from the hard level ground.

## Load Chart of Fixed Jib

Load table of fixed jib FJ working condition of SCC1350E crawler crane

Radius (m)	Auxiliary hook, boom 17-65m, jib 31m, and boom to jib angle 15° Unit: t							Radius (m)
	17	23	29	35	38	41	44	
14	8.4	8.5	8.5					14
16	8.4	8.6	8.6	8.3	8.2	8.0	7.9	16
18	8.4	8.6	8.6	8.4	8.2	8.1	7.9	18
20	8.4	8.5	8.6	8.4	8.3	8.1	7.9	20
22	8.4	8.5	8.6	8.4	8.2	8.1	7.9	22
24	8.1	8.4	8.6	8.4	8.3	8.2	8.0	24
26	7.7	8.1	8.4	8.3	8.2	8.2	8.0	26
28	7.3	7.7	8.0	8.0	8.0	8.0	8.0	28
30	6.9	7.3	7.6	7.8	7.8	7.8	7.8	30
32	6.6	7.0	7.3	7.6	7.6	7.7	7.7	32
34	6.3	6.7	7.0	7.4	7.5	7.5	7.5	34
36	6.0	6.4	6.7	7.2	7.3	7.3	7.3	36
38	5.7	6.2	6.5	6.9	7.0	7.1	7.1	38
40	5.5	5.9	6.3	6.6	6.8	6.9	7.0	40
42	5.2	5.7	6.0	6.4	6.6	6.7	6.8	42
44	5.0	5.5	5.8	6.2	6.4	6.5	6.6	44
46	4.8	5.2	5.5	6.0	6.1	6.3	6.4	46
48		5.1	5.3	5.8	6.0	6.1	6.2	48
50		4.9	5.2	5.6	5.7	5.9	6.0	50
52			5.0	5.4	5.6	5.7	5.9	52
54			4.8	5.3	5.4	5.5	5.7	54
56			4.7	5.1	5.2	5.4	5.5	56
58				5.0	5.1	5.2	5.1	58
60				4.9	5.0	4.9	4.8	60
62					4.8	4.6	4.4	62
64					4.5	4.3	4.1	64
66						4.0	3.8	66
68							3.6	68
70								70
72								72
74								74
76								76
Counterweight	54+20	54+20	54+20	54+20	54+20	54+20	54+20	Counterweight
Rate	1	1	1	1	1	1	1	Rate

Notes:

1. The actual lifting weight is equal to the value that the rated lifting weight in the table subtracts the weight of all the lifting devices such as lifting hook
2. The rated lifting weight in the table is the weight of the non-traveling weight which is lifted slowly and steadily from the hard level ground.

## Load Chart of Fixed Jib

Load table of fixed jib FJ working condition of SCC1350E crawler crane

Length (m)		Auxiliary hook, boom 17-65m, jib 31m, and boom to jib angle 15° Unit: t						Length (m)	
Radius (m)	47	50	53	56	59	62	65	Radius (m)	
14								14	
16	7.6	7.4	7.2	6.9	6.7			16	
18	7.7	7.5	7.2	7.0	6.7	6.4	6.0	18	
20	7.7	7.5	7.3	7.0	6.7	6.4	6.0	20	
22	7.8	7.5	7.3	7.0	6.7	6.4	6.1	22	
24	7.8	7.6	7.3	7.0	6.8	6.5	6.1	24	
26	7.8	7.6	7.4	7.0	6.8	6.5	6.0	26	
28	7.9	7.6	7.4	7.1	6.8	6.5	6.1	28	
30	7.8	7.6	7.4	7.1	6.8	6.5	6.1	30	
32	7.7	7.6	7.4	7.1	6.8	6.5	6.1	32	
34	7.5	7.5	7.4	7.2	6.8	6.5	6.1	34	
36	7.3	7.3	7.3	7.2	6.9	6.5	6.1	36	
38	7.2	7.2	7.2	7.1	6.9	6.5	6.1	38	
40	7.0	7.0	7.0	7.0	6.9	6.5	6.1	40	
42	6.9	6.9	6.9	6.9	6.9	6.5	6.1	42	
44	6.7	6.7	6.7	6.7	6.7	6.6	6.1	44	
46	6.5	6.6	6.6	6.6	6.6	6.6	6.1	46	
48	6.3	6.4	6.5	6.5	6.5	6.3	6.1	48	
50	6.1	6.3	6.3	6.1	6.0	5.8	5.6	50	
52	6.0	6.0	5.8	5.7	5.5	5.3	5.2	52	
54	5.8	5.6	5.4	5.2	5.1	4.9	4.7	54	
56	5.4	5.2	5.0	4.8	4.7	4.5	4.3	56	
58	5.0	4.8	4.6	4.4	4.3	4.1	4.0	58	
60	4.6	4.5	4.3	4.1	4.0	3.8	3.6	60	
62	4.3	4.1	4.0	3.8	3.6	3.5	3.3	62	
64	4.0	3.8	3.7	3.5	3.3	3.2	3.0	64	
66	3.7	3.5	3.4	3.2	3.1	2.9	2.7	66	
68	3.4	3.3	3.1	2.9	2.8	2.6	2.4	68	
70	3.2	3.0	2.8	2.7	2.5	2.3	2.2	70	
72	2.9	2.8	2.6	2.4	2.3	2.1		72	
74		2.5	2.4	2.2	2.1			74	
76			2.1					76	
Counterweight	54+20	54+20	54+20	54+20	54+20	54+20	54+20	Counterweight	
Rate	1	1	1	1	1	1	1	Rate	

Notes:  
 1. The actual lifting weight is equal to the value that the rated lifting weight in the table subtracts the weight of all the lifting devices such as lifting hook  
 2. The rated lifting weight in the table is the weight of the non-traveling weight which is lifted slowly and steadily from the hard level ground.

## Load Chart of Fixed Jib

Load table of fixed jib FJ working condition of SCC1350E crawler crane

Length (m)		Auxiliary hook, boom 17-71m, jib 13m, and boom to jib angle 30° Unit: t						Length (m)	
Radius (m)	17	23	29	35	38	41	44	47	Radius (m)
11	23.5	23.3							11
12	22.3	22.4	22.6	22.3	22.3	22.2			12
14	21.2	21.8	21.8	21.9	21.8	21.7	21.7	21.6	14
16	19.6	20.8	21.3	21.4	21.4	21.2	21.2	21.2	16
18	18.3	19.5	20.5	20.7	20.8	20.8	20.9	20.7	18
20	17.2	18.5	19.5	20.3	20.4	20.4	20.5	20.4	20
22	16.3	17.6	18.7	19.3	20.0	20.1	20.1	20.0	22
24	15.5	16.8	17.9	18.2	19.2	19.6	19.8	19.6	24
26	15.0	16.2	17.3	17.2	18.1	18.0	17.8	17.7	26
28	14.3	15.6	16.7	16.5	16.3	16.2	16.0	15.9	28
30		15.2	15.3	15.0	14.8	14.7	14.5	14.4	30
32		14.3	14.0	13.7	13.5	13.3	13.2	13.1	32
34		13.1	12.8	12.5	12.3	12.2	12.0	11.9	34
36			11.8	11.5	11.3	11.2	11.0	10.9	36
38			10.9	10.6	10.4	10.3	10.1	10.0	38
40				9.8	9.6	9.4	9.3	9.2	40
42				9.0	8.8	8.7	8.5	8.4	42
44				8.3	8.2	8.0	7.8	7.7	44
46					7.5	7.4	7.2	7.1	46
48						6.8	6.7	6.6	48
50						6.3	6.1	6.1	50
52							5.6	5.6	52
54								5.1	54
56									56
58									58
60									60
62									62
64									64
66									66
Counterweight	54+20	54+20	54+20	54+20	54+20	54+20	54+20	54+20	Counterweight
Rate	2	2	2	2	2	2	2	2	Rate

Notes:  
 1. The actual lifting weight is equal to the value that the rated lifting weight in the table subtracts the weight of all the lifting devices such as lifting hook  
 2. The rated lifting weight in the table is the weight of the non-traveling weight which is lifted slowly and steadily from the hard level ground.

## Load Chart of Fixed Jib

Load table of fixed jib FJ working condition of SCC1350E crawler crane

Radius (m)	Auxiliary hook, boom 17-71m, jib 13m, and boom to jib angle 30° Unit: t								Radius (m)
	50	53	56	59	62	65	68	71	
11									11
12									12
14	21.1	19.6	18.1	16.8	15.5	14.4	13.2	12.1	14
16	21.0	19.8	18.3	17.0	15.6	14.3	13.1	12.1	16
18	20.6	20.0	18.3	17.0	15.6	14.4	13.1	12.1	18
20	20.3	20.1	18.5	17.1	15.6	14.4	13.1	12.1	20
22	20.0	19.9	18.6	17.2	15.7	14.4	13.2	12.1	22
24	19.6	19.4	18.7	17.2	15.8	14.4	13.1	12.0	24
26	17.5	17.3	17.2	17.0	15.8	14.4	13.1	12.0	26
28	15.7	15.6	15.4	15.3	15.1	14.4	13.0	12.0	28
30	14.2	14.0	13.9	13.7	13.6	13.4	13.1	11.9	30
32	12.9	12.7	12.5	12.4	12.2	12.1	11.9	11.8	32
34	11.7	11.6	11.4	11.3	11.1	10.9	10.7	10.6	34
36	10.7	10.5	10.4	10.2	10.1	9.9	9.7	9.6	36
38	9.8	9.6	9.4	9.3	9.1	9.0	8.8	8.7	38
40	9.0	8.8	8.6	8.5	8.3	8.2	8.0	7.8	40
42	8.2	8.1	7.9	7.8	7.6	7.4	7.2	7.1	42
44	7.6	7.4	7.2	7.1	6.9	6.7	6.6	6.4	44
46	7.0	6.8	6.6	6.5	6.3	6.1	6.0	5.8	46
48	6.4	6.2	6.0	5.9	5.7	5.6	5.4	5.3	48
50	5.9	5.7	5.5	5.4	5.2	5.1	4.9	4.8	50
52	5.4	5.2	5.1	4.9	4.8	4.6	4.4	4.3	52
54	4.9	4.8	4.6	4.5	4.3	4.2	4.0	3.8	54
56	4.5	4.4	4.2	4.1	3.9	3.7	3.6	3.4	56
58	4.1	4.0	3.8	3.7	3.5	3.4	3.2	2.6	58
60		3.6	3.4	3.3	3.2	3.0	2.8		60
62			3.1	3.0	2.8	2.7	2.1		62
64				2.7	2.5	2.4			64
66					2.2	2.1			66
Counterweight	54+20	54+20	54+20	54+20	54+20	54+20	54+20	54+20	Counterweight
Rate	2	2	2	2	2	2	2	2	Rate

Notes:

1. The actual lifting weight is equal to the value that the rated lifting weight in the table subtracts the weight of all the lifting devices such as lifting hook
2. The rated lifting weight in the table is the weight of the non-traveling weight which is lifted slowly and steadily from the hard level ground.

## Load Chart of Fixed Jib

Load table of fixed jib FJ working condition of SCC1350E crawler crane

Radius (m)	Auxiliary hook, boom 17-71m, jib 16m, and boom to jib angle 30° Unit: t								Radius (m)
	17	23	29	35	38	41	44	47	
12	19.6								12
14	18.7	18.9	19.0	18.8	18.8	18.6	18.5	18.0	14
16	17.6	18.3	18.3	18.3	18.3	18.2	18.2	18.0	16
18	16.4	17.3	17.9	17.9	18.0	17.9	17.8	17.7	18
20	15.3	16.3	17.1	17.5	17.6	17.4	17.5	17.4	20
22	14.5	15.5	16.3	17.0	17.2	17.2	17.2	17.2	22
24	13.7	14.7	15.6	16.3	16.6	16.8	16.8	16.8	24
26	13.1	14.1	15.0	15.7	16.0	16.3	16.6	16.5	26
28	12.6	13.6	14.4	15.2	15.5	15.8	16.1	16.2	28
30	12.2	13.1	13.9	14.7	15.0	14.9	14.8	14.7	30
32	12.0	12.7	13.5	13.9	13.8	13.6	13.4	13.3	32
34		12.4	13.1	12.8	12.6	12.4	12.3	12.2	34
36		12.3	12.1	11.7	11.6	11.4	11.2	11.1	36
38			11.1	10.8	10.7	10.5	10.3	10.2	38
40			10.3	10.0	9.8	9.7	9.5	9.4	40
42			9.5	9.2	9.1	8.9	8.8	8.7	42
44				8.6	8.4	8.3	8.1	8.0	44
46				7.9	7.8	7.6	7.5	7.4	46
48				7.3	7.2	7.1	6.9	6.8	48
50					6.7	6.5	6.4	6.3	50
52						6.0	5.9	5.8	52
54							5.4	5.3	54
56								4.9	56
58								4.5	58
60									60
62									62
64									64
66									66
68									68
Counterweight	54+20	54+20	54+20	54+20	54+20	54+20	54+20	54+20	Counterweight
Rate	2	2	2	2	2	2	2	2	Rate

Notes:

1. The actual lifting weight is equal to the value that the rated lifting weight in the table subtracts the weight of all the lifting devices such as lifting hook
2. The rated lifting weight in the table is the weight of the non-traveling weight which is lifted slowly and steadily from the hard level ground.

## Load Chart of Fixed Jib

Load table of fixed jib FJ working condition of SCC1350E crawler crane

Radius (m)	Auxiliary hook, boom 17-71m, jib 16m, and boom to jib angle 30° Unit: t								Radius (m)
	Length (m)								
	50	53	56	59	62	65	68	71	
12									12
14									14
16	17.1	16.0	14.9	13.9	13.0	12.0	11.0	10.3	16
18	17.3	16.3	15.0	14.1	13.0	12.1	11.1	10.3	18
20	17.3	16.5	15.2	14.2	13.1	12.1	11.1	10.3	20
22	17.1	16.7	15.3	14.3	13.2	12.1	11.1	10.3	22
24	16.8	16.7	15.5	14.3	13.3	12.2	11.2	10.3	24
26	16.5	16.6	15.7	14.5	13.3	12.2	11.1	10.3	26
28	16.0	15.9	15.7	14.6	13.4	12.3	11.2	10.2	28
30	14.5	14.4	14.2	14.1	13.4	12.3	11.2	10.3	30
32	13.2	13.0	12.9	12.7	12.6	12.3	11.2	10.3	32
34	12.0	11.8	11.7	11.6	11.4	11.2	11.1	10.2	34
36	11.0	10.8	10.6	10.5	10.4	10.2	10.0	9.9	36
38	10.1	9.9	9.7	9.6	9.4	9.3	9.1	9.0	38
40	9.2	9.1	8.9	8.8	8.6	8.4	8.3	8.1	40
42	8.5	8.3	8.1	8.0	7.9	7.7	7.5	7.4	42
44	7.8	7.6	7.5	7.4	7.2	7.0	6.8	6.7	44
46	7.2	7.0	6.9	6.7	6.6	6.4	6.2	6.1	46
48	6.6	6.5	6.3	6.2	6.0	5.8	5.6	5.5	48
50	6.1	5.9	5.8	5.7	5.5	5.3	5.1	5.0	50
52	5.6	5.5	5.3	5.2	5.0	4.8	4.6	4.5	52
54	5.2	5.0	4.8	4.7	4.5	4.4	4.2	4.1	54
56	4.7	4.6	4.4	4.3	4.1	4.0	3.8	3.7	56
58	4.4	4.2	4.0	3.9	3.7	3.6	3.4	3.3	58
60	4.0	3.8	3.7	3.6	3.4	3.2	3.0	2.9	60
62		3.5	3.3	3.2	3.0	2.9	2.7	2.3	62
64			3.0	2.9	2.7	2.6	2.4		64
66			2.7	2.6	2.4	2.3			66
68				2.3	2.1				68
Counterweight	54+20	54+20	54+20	54+20	54+20	54+20	54+20	54+20	Counterweight
Rate	2	2	2	2	2	2	1	1	Rate

Notes:

1. The actual lifting weight is equal to the value that the rated lifting weight in the table subtracts the weight of all the lifting devices such as lifting hook
2. The rated lifting weight in the table is the weight of the non-traveling weight which is lifted slowly and steadily from the hard level ground.

## Load Chart of Fixed Jib

Load table of fixed jib FJ working condition of SCC1350E crawler crane

Radius (m)	Auxiliary hook, boom 17-68m, jib 19m, and boom to jib angle 30° Unit: t								Radius (m)
	Length (m)								
	17	23	29	35	38	41	44	47	
14	16.6	16.5							14
16	15.9	16.0	16.0	15.9	15.8	15.8	15.2	14.6	16
18	15.0	15.5	15.6	15.6	15.6	15.4	15.4	14.8	18
20	14.0	14.7	15.2	15.2	15.3	15.2	15.2	15.1	20
22	13.1	13.9	14.5	14.9	14.9	14.9	14.9	14.8	22
24	12.4	13.2	13.9	14.4	14.6	14.7	14.6	14.6	24
26	11.8	12.6	13.3	13.9	14.1	14.4	14.4	14.3	26
28	11.2	12.1	12.8	13.4	13.7	13.9	14.1	14.2	28
30	10.8	11.6	12.3	12.9	13.2	13.5	13.7	13.9	30
32	10.4	11.2	11.9	12.5	12.8	13.1	13.3	13.6	32
34	10.2	10.9	11.5	12.2	12.4	12.7	12.5	12.4	34
36		10.6	11.2	11.9	11.8	11.6	11.5	11.4	36
38		10.4	10.9	11.0	10.9	10.7	10.5	10.4	38
40		10.3	10.5	10.2	10.0	9.9	9.7	9.6	40
42			9.7	9.4	9.3	9.1	9.0	8.9	42
44			9.0	8.8	8.6	8.4	8.3	8.2	44
46				8.1	8.0	7.8	7.7	7.6	46
48				7.5	7.4	7.2	7.1	7.0	48
50				7.0	6.9	6.7	6.6	6.5	50
52					6.4	6.2	6.1	6.0	52
54						5.8	5.6	5.5	54
56						5.3	5.2	5.1	56
58							4.8	4.7	58
60								4.3	60
62									62
64									64
66									66
68									68
70									70
Counterweight	54+20	54+20	54+20	54+20	54+20	54+20	54+20	54+20	Counterweight
Rate	2	2	2	2	2	2	2	2	Rate

Notes:

1. The actual lifting weight is equal to the value that the rated lifting weight in the table subtracts the weight of all the lifting devices such as lifting hook
2. The rated lifting weight in the table is the weight of the non-traveling weight which is lifted slowly and steadily from the hard level ground.

## Load Chart of Fixed Jib

Load table of fixed jib FJ working condition of SCC1350E crawler crane

Radius (m)	Length (m) Auxiliary hook, boom 17-68m, jib 19m, and boom to jib angle 30° Unit: t							Radius (m)
	50	53	56	59	62	65	68	
14								14
16	13.7							16
18	13.9	13.1	12.3	11.6	10.8	10.0	9.3	18
20	14.1	13.3	12.4	11.7	10.9	10.1	9.4	20
22	14.4	13.5	12.5	11.8	10.9	10.2	9.4	22
24	14.6	13.7	12.7	11.9	11.1	10.2	9.4	24
26	14.3	13.9	12.9	12.1	11.2	10.3	9.4	26
28	14.1	14.1	13.0	12.2	11.3	10.3	9.5	28
30	13.9	13.9	13.2	12.2	11.3	10.4	9.5	30
32	13.4	13.3	13.1	12.4	11.4	10.5	9.5	32
34	12.2	12.1	11.9	11.8	11.5	10.5	9.6	34
36	11.2	11.1	10.9	10.8	10.6	10.5	9.6	36
38	10.3	10.1	10.0	9.8	9.7	9.5	9.4	38
40	9.4	9.3	9.1	9.0	8.8	8.7	8.5	40
42	8.7	8.5	8.4	8.3	8.1	7.9	7.8	42
44	8.0	7.9	7.7	7.6	7.4	7.2	7.1	44
46	7.4	7.2	7.1	6.9	6.8	6.6	6.4	46
48	6.8	6.7	6.5	6.4	6.2	6.0	5.9	48
50	6.3	6.1	6.0	5.8	5.7	5.5	5.3	50
52	5.8	5.6	5.5	5.4	5.2	5.0	4.9	52
54	5.3	5.2	5.0	4.9	4.7	4.6	4.4	54
56	4.9	4.8	4.6	4.5	4.3	4.2	4.0	56
58	4.5	4.4	4.2	4.1	3.9	3.8	3.6	58
60	4.2	4.0	3.8	3.7	3.6	3.4	3.2	60
62	3.8	3.7	3.5	3.4	3.2	3.1	2.9	62
64	3.5	3.3	3.2	3.1	2.9	2.7	2.6	64
66		3.0	2.8	2.8	2.6	2.4	2.2	66
68			2.5	2.5	2.3	2.1		68
70				2.2	2.0			70
Counterweight	54+20	54+20	54+20	54+20	54+20	54+20	54+20	Counterweight
Rate	2	2	2	2	1	1	1	Rate

Notes:

1. The actual lifting weight is equal to the value that the rated lifting weight in the table subtracts the weight of all the lifting devices such as lifting hook
2. The rated lifting weight in the table is the weight of the non-traveling weight which is lifted slowly and steadily from the hard level ground.

## Load Chart of Fixed Jib

Load table of fixed jib FJ working condition of SCC1350E crawler crane

Radius (m)	Length (m) Auxiliary hook, boom 17-68m, jib 22m, and boom to jib angle 30° Unit: t							Radius (m)	
	17	23	29	35	38	41	44		47
16	14.0	13.5							16
18	12.9	13.1	13.1	13.1	13.0	13.0	12.3	11.9	18
20	12.1	12.6	12.8	12.8	12.7	12.8	12.6	12.1	20
22	11.3	11.8	12.3	12.4	12.4	12.4	12.5	12.3	22
24	10.6	11.2	11.7	12.1	12.2	12.3	12.2	12.2	24
26	10.1	10.7	11.2	11.6	11.8	12.0	12.0	11.9	26
28	9.6	10.2	10.8	11.2	11.4	11.6	11.7	11.7	28
30	9.1	9.8	10.3	10.8	11.0	11.2	11.4	11.6	30
32	8.8	9.4	10.0	10.5	10.7	10.9	11.1	11.3	32
34	8.5	9.1	9.7	10.1	10.4	10.6	10.8	11.0	34
36	8.2	8.8	9.3	9.8	9.9	10.3	10.5	10.7	36
38	7.8	8.6	9.1	9.6	9.7	10.0	10.2	10.4	38
40		8.4	8.9	9.3	9.6	9.8	9.9	9.8	40
42		8.2	8.7	9.1	9.5	9.3	9.2	9.1	42
44			8.5	8.9	8.8	8.6	8.5	8.4	44
46			8.4	8.3	8.2	8.0	7.9	7.8	46
48			8.0	7.7	7.6	7.4	7.3	7.2	48
50				7.2	7.1	6.9	6.8	6.7	50
52				6.7	6.6	6.4	6.3	6.2	52
54				6.2	6.1	6.0	5.8	5.7	54
56					5.6	5.5	5.4	5.3	56
58						5.1	5.0	4.9	58
60							4.6	4.5	60
62								4.1	62
64								3.8	64
66									66
68									68
70									70
72									72
Counterweight	54+20	54+20	54+20	54+20	54+20	54+20	54+20	54+20	Counterweight
Rate	2	2	2	2	2	2	2	2	Rate

Notes:

1. The actual lifting weight is equal to the value that the rated lifting weight in the table subtracts the weight of all the lifting devices such as lifting hook
2. The rated lifting weight in the table is the weight of the non-traveling weight which is lifted slowly and steadily from the hard level ground.



## Load Chart of Fixed Jib

Load table of fixed jib FJ working condition of SCC1350E crawler crane

Radius (m)	Length (m) Auxiliary hook, boom 17-68m, jib 22m, and boom to jib angle 30° Unit: t							Radius (m)
	50	53	56	59	62	65	68	
16								16
18	11.1	10.7	10.0					18
20	11.3	10.8	10.1	9.6	9.0	8.4	7.8	20
22	11.6	11.0	10.2	9.8	9.1	8.4	7.8	22
24	11.7	11.2	10.4	9.9	9.2	8.6	7.9	24
26	11.9	11.3	10.5	10.0	9.2	8.6	7.9	26
28	11.8	11.5	10.7	10.1	9.3	8.7	8.0	28
30	11.6	11.6	10.9	10.2	9.4	8.8	8.1	30
32	11.4	11.4	11.0	10.3	9.6	8.8	8.1	32
34	11.2	11.2	11.2	10.5	9.6	8.9	8.2	34
36	11.1	11.0	11.1	10.5	9.7	9.0	8.2	36
38	10.5	10.4	10.2	10.1	9.8	9.0	8.2	38
40	9.7	9.5	9.4	9.2	9.1	8.9	8.3	40
42	8.9	8.8	8.6	8.5	8.3	8.2	8.0	42
44	8.2	8.1	7.9	7.8	7.6	7.5	7.3	44
46	7.6	7.4	7.3	7.2	7.0	6.9	6.7	46
48	7.0	6.9	6.7	6.6	6.4	6.3	6.1	48
50	6.5	6.3	6.2	6.1	5.9	5.7	5.6	50
52	6.0	5.8	5.7	5.6	5.4	5.2	5.1	52
54	5.5	5.4	5.2	5.1	4.9	4.8	4.6	54
56	5.1	5.0	4.8	4.7	4.5	4.4	4.2	56
58	4.7	4.6	4.4	4.3	4.1	4.0	3.8	58
60	4.3	4.2	4.0	3.9	3.8	3.6	3.4	60
62	4.0	3.8	3.7	3.6	3.4	3.2	3.1	62
64	3.7	3.5	3.4	3.2	3.1	2.9	2.7	64
66	3.3	3.2	3.0	2.9	2.8	2.6	2.4	66
68		2.9	2.7	2.6	2.5	2.3	2.1	68
70			2.5	2.4	2.2	2.0		70
72			2.2	2.1				72
Counterweight	54+20	54+20	54+20	54+20	54+20	54+20	54+20	Counterweight
Rate	1	1	1	1	1	1	1	Rate

Notes:

1. The actual lifting weight is equal to the value that the rated lifting weight in the table subtracts the weight of all the lifting devices such as lifting hook
2. The rated lifting weight in the table is the weight of the non-traveling weight which is lifted slowly and steadily from the hard level ground.

## Load Chart of Fixed Jib

Load table of fixed jib FJ working condition of SCC1350E crawler crane

Radius (m)	Length (m) Auxiliary hook, boom 17-68m, jib 25m, and boom to jib angle 30° Unit: t								Radius (m)
	17	23	29	35	38	41	44	47	
18	11.4	11.6	11.6						18
20	10.9	11.3	11.3	11.1	10.7	10.4	9.9	9.6	20
22	10.6	11.0	11.0	11.0	10.9	10.6	10.1	9.7	22
24	9.9	10.4	10.7	10.8	10.8	10.7	10.4	9.9	24
26	9.4	9.9	10.3	10.5	10.6	10.5	10.3	10.1	26
28	8.9	9.4	9.9	10.2	10.3	10.4	10.3	10.3	28
30	8.5	9.0	9.5	9.9	10.0	10.1	10.2	10.2	30
32	8.1	8.6	9.1	9.5	9.7	9.9	10.0	10.0	32
34	7.8	8.3	8.8	9.2	9.4	9.6	9.7	9.9	34
36	7.5	8.0	8.5	8.9	9.1	9.3	9.5	9.6	36
38	7.2	7.8	8.2	8.7	8.8	9.0	9.2	9.4	38
40	7.1	7.5	8.0	8.4	8.6	8.8	9.0	9.1	40
42		7.4	7.8	8.2	8.4	8.6	8.8	8.9	42
44		7.2	7.6	8.0	8.2	8.4	8.6	8.5	44
46		7.1	7.5	7.8	8.0	8.2	8.0	7.9	46
48			7.3	7.7	7.7	7.6	7.4	7.3	48
50			7.3	7.3	7.2	7.1	6.9	6.8	50
52				6.8	6.7	6.6	6.4	6.3	52
54				6.4	6.2	6.1	5.9	5.9	54
56				5.9	5.8	5.7	5.5	5.4	56
58					5.4	5.3	5.1	5.0	58
60						4.9	4.7	4.7	60
62						4.5	4.4	4.3	62
64							4.0	4.0	64
66								3.6	66
68									68
70									70
72									72
74									74
Counterweight	54+20	54+20	54+20	54+20	54+20	54+20	54+20	54+20	Counterweight
Rate	1	1	1	1	1	1	1	1	Rate

Notes:

1. The actual lifting weight is equal to the value that the rated lifting weight in the table subtracts the weight of all the lifting devices such as lifting hook
2. The rated lifting weight in the table is the weight of the non-traveling weight which is lifted slowly and steadily from the hard level ground.

## Load Chart of Fixed Jib

Load table of fixed jib FJ working condition of SCC1350E crawler crane

Radius (m)	Auxiliary hook, boom 17-68m, jib 25m, and boom to jib angle 30° Unit: t								Radius (m)
	50	53	56	59	62	65	68	47	
18									18
20	9.1	8.7	8.2	7.9				9.6	20
22	9.3	8.9	8.4	7.9	7.5	7.0	6.5	9.7	22
24	9.5	9.0	8.5	8.1	7.6	7.1	6.6	9.9	24
26	9.6	9.2	8.6	8.2	7.7	7.1	6.6	10.1	26
28	9.8	9.3	8.8	8.3	7.7	7.2	6.7	10.3	28
30	9.9	9.5	8.9	8.4	7.8	7.3	6.7	10.2	30
32	10.0	9.7	9.0	8.5	7.9	7.4	6.8	10.0	32
34	9.8	9.8	9.1	8.6	8.0	7.4	6.9	9.9	34
36	9.7	9.7	9.3	8.7	8.1	7.5	6.9	9.6	36
38	9.5	9.5	9.4	8.9	8.2	7.6	6.9	9.4	38
40	9.3	9.5	9.4	9.0	8.3	7.6	7.0	9.1	40
42	9.1	8.9	8.8	8.7	8.4	7.7	7.1	8.9	42
44	8.4	8.2	8.1	8.0	7.8	7.7	7.1	8.5	44
46	7.7	7.6	7.4	7.3	7.2	7.0	6.9	7.9	46
48	7.2	7.0	6.9	6.8	6.6	6.5	6.3	7.3	48
50	6.6	6.5	6.3	6.2	6.1	5.9	5.8	6.8	50
52	6.1	6.0	5.8	5.7	5.6	5.4	5.3	6.3	52
54	5.7	5.5	5.4	5.3	5.1	5.0	4.8	5.9	54
56	5.3	5.1	5.0	4.8	4.7	4.5	4.4	5.4	56
58	4.9	4.7	4.6	4.5	4.3	4.1	4.0	5.0	58
60	4.5	4.4	4.2	4.1	3.9	3.8	3.6	4.7	60
62	4.1	4.0	3.8	3.7	3.6	3.4	3.2	4.3	62
64	3.8	3.7	3.5	3.4	3.2	3.1	2.9	4.0	64
66	3.5	3.4	3.2	3.1	2.9	2.8	2.6	3.6	66
68	3.2	3.1	2.9	2.8	2.6	2.5	2.3		68
70	2.9	2.8	2.6	2.5	2.3	2.2	2.0		70
72		2.5	2.3	2.2	2.1				72
74			2.1						74
Counterweight	54+20	54+20	54+20	54+20	54+20	54+20	54+20	54+20	Counterweight
Rate	1	1	1	1	1	1	1	1	Rate

Notes:

1. The actual lifting weight is equal to the value that the rated lifting weight in the table subtracts the weight of all the lifting devices such as lifting hook
2. The rated lifting weight in the table is the weight of the non-traveling weight which is lifted slowly and steadily from the hard level ground.

## Load Chart of Fixed Jib

Load table of fixed jib FJ working condition of SCC1350E crawler crane

Radius (m)	Auxiliary hook, boom 17-65m, jib 28m, and boom to jib angle 30° Unit: t								Radius (m)
	17	23	29	35	38	41	44		
20	9.2	9.4	9.1	8.7					20
22	8.9	9.6	9.3	8.8	8.6	8.4	8.0		22
24	8.6	9.4	9.5	9.1	8.8	8.5	8.1		24
26	8.2	9.1	9.2	9.2	8.9	8.7	8.3		26
28	7.9	8.8	8.9	9.0	9.1	8.9	8.5		28
30	7.6	8.4	8.6	8.8	8.8	8.9	8.7		30
32	7.2	8.0	8.4	8.6	8.6	8.7	8.7		32
34	7.0	7.7	8.1	8.3	8.4	8.4	8.5		34
36	6.7	7.4	7.8	8.1	8.2	8.2	8.3		36
38	6.6	7.2	7.6	7.9	8.0	8.0	8.1		38
40	6.4	7.0	7.3	7.7	7.8	7.9	8.0		40
42	6.3	6.8	7.1	7.5	7.6	7.7	7.8		42
44	6.2	6.6	6.9	7.3	7.5	7.6	7.7		44
46		6.5	6.8	7.1	7.2	7.4	7.5		46
48		6.4	6.6	7.0	7.1	7.3	7.4		48
50			6.5	6.8	7.0	7.2	7.0		50
52			6.4	6.7	6.8	6.7	6.6		52
54			6.4	6.5	6.4	6.2	6.1		54
56				6.1	6.0	5.8	5.7		56
58				5.7	5.5	5.4	5.3		58
60				5.3	5.2	5.0	4.9		60
62					4.8	4.7	4.5		62
64						4.3	4.2		64
66							3.9		66
68									68
70									70
72									72
74									74
Counterweight	54+20	54+20	54+20	54+20	54+20	54+20	54+20	Counterweight	
Rate	1	1	1	1	1	1	1	Rate	

Notes:

1. The actual lifting weight is equal to the value that the rated lifting weight in the table subtracts the weight of all the lifting devices such as lifting hook
2. The rated lifting weight in the table is the weight of the non-traveling weight which is lifted slowly and steadily from the hard level ground.

## Load Chart of Fixed Jib

Load table of fixed jib FJ working condition of SCC1350E crawler crane

Radius (m)	Auxiliary hook, boom 17-65m, jib 28m, and boom to jib angle 30° Unit: t							Radius (m)	
	Length (m)	47	50	53	56	59	62		65
20									20
22	7.8	7.4	7.1	6.8	6.5	6.2	5.7		22
24	8.0	7.6	7.3	6.9	6.6	6.2	5.8		24
26	8.1	7.7	7.4	7.0	6.7	6.3	5.9		26
28	8.3	7.8	7.5	7.1	6.8	6.4	6.0		28
30	8.4	8.0	7.6	7.2	6.9	6.5	6.0		30
32	8.5	8.1	7.8	7.3	7.0	6.5	6.1		32
34	8.5	8.3	7.9	7.4	7.1	6.6	6.2		34
36	8.3	8.4	8.0	7.6	7.2	6.7	6.2		36
38	8.2	8.2	8.2	7.7	7.3	6.8	6.3		38
40	8.0	8.0	8.1	7.8	7.4	6.9	6.3		40
42	7.9	7.9	8.0	7.9	7.5	7.0	6.4		42
44	7.7	7.7	7.8	7.9	7.6	7.0	6.5		44
46	7.6	7.6	7.7	7.6	7.5	7.1	6.6		46
48	7.5	7.3	7.2	7.0	6.9	6.8	6.6		48
50	6.9	6.8	6.7	6.5	6.4	6.2	6.1		50
52	6.5	6.3	6.2	6.0	5.9	5.7	5.6		52
54	6.0	5.8	5.7	5.5	5.4	5.3	5.1		54
56	5.6	5.4	5.3	5.1	5.0	4.9	4.7		56
58	5.2	5.0	4.9	4.7	4.6	4.5	4.3		58
60	4.8	4.6	4.5	4.3	4.2	4.1	3.9		60
62	4.4	4.3	4.2	4.0	3.9	3.7	3.6		62
64	4.1	4.0	3.8	3.7	3.6	3.4	3.2		64
66	3.8	3.6	3.5	3.3	3.2	3.1	2.9		66
68	3.5	3.3	3.2	3.1	2.9	2.8	2.6		68
70	3.2	3.1	2.9	2.8	2.7	2.5	2.4		70
72		2.8	2.6	2.5	2.4	2.2	2.1		72
74			2.4	2.2	2.1				74
Counterweight	54+20	54+20	54+20	54+20	54+20	54+20	54+20	Counterweight	
Rate	1	1	1	1	1	1	1	Rate	

Notes:

1. The actual lifting weight is equal to the value that the rated lifting weight in the table subtracts the weight of all the lifting devices such as lifting hook
2. The rated lifting weight in the table is the weight of the non-traveling weight which is lifted slowly and steadily from the hard level ground.

## Load Chart of Fixed Jib

Load table of fixed jib FJ working condition of SCC1350E crawler crane

Radius (m)	Auxiliary hook, boom 17-65m, jib 31m, and boom to jib angle 30° Unit: t							Radius (m)	
	Length (m)	17	23	29	35	38	41		44
22	7.5	7.4	7.2	6.9	6.7	6.6			22
24	7.1	7.3	7.3	7.0	6.8	6.7	6.4		24
26	6.8	7.0	7.0	7.1	7.0	6.8	6.6		26
28	6.5	6.7	6.8	7.0	7.1	6.9	6.7		28
30	6.2	6.4	6.5	6.8	6.8	6.9	6.8		30
32	6.0	6.2	6.3	6.6	6.6	6.7	6.8		32
34	5.7	6.0	6.1	6.4	6.4	6.5	6.6		34
36	5.5	5.8	5.9	6.2	6.2	6.3	6.4		36
38	5.3	5.6	5.7	6.0	6.1	6.2	6.2		38
40	5.1	5.4	5.6	5.8	5.9	6.0	6.1		40
42	4.9	5.2	5.4	5.7	5.8	5.8	5.9		42
44	4.8	5.1	5.2	5.5	5.6	5.7	5.7		44
46	4.8	4.9	5.1	5.4	5.5	5.6	5.6		46
48		4.9	4.9	5.2	5.3	5.4	5.5		48
50		4.8	4.8	5.1	5.2	5.3	5.4		50
52		4.8	4.7	5.0	5.1	5.2	5.3		52
54			4.7	4.9	5.0	5.1	5.1		54
56			4.7	4.9	4.9	5.0	5.0		56
58				4.8	4.9	4.9	5.0		58
60				4.8	4.9	4.9	4.9		60
62				4.9	4.8	4.8	4.7		62
64					4.6	4.5	4.3		64
66						4.1	4.0		66
68						3.8	3.7		68
70							3.4		70
72									72
74									74
76									76
78									78
Counterweight	54+20	54+20	54+20	54+20	54+20	54+20	54+20	Counterweight	
Rate	1	1	1	1	1	1	1	Rate	

Notes:

1. The actual lifting weight is equal to the value that the rated lifting weight in the table subtracts the weight of all the lifting devices such as lifting hook
2. The rated lifting weight in the table is the weight of the non-traveling weight which is lifted slowly and steadily from the hard level ground.

## Load Chart of Fixed Jib

### Load table of fixed jib FJ working condition of SCC1350E crawler crane

Length (m)		Auxiliary hook, boom 17-65m, jib 31m, and boom to jib angle 30°						Length (m)	
Radius (m)	47	50	53	56	59	62	65	Radius (m)	
22								22	
24	6.3	6.0	5.9	5.6	5.4	5.1	4.8	24	
26	6.4	6.1	5.9	5.7	5.4	5.1	4.8	26	
28	6.6	6.3	6.0	5.8	5.5	5.2	4.9	28	
30	6.6	6.3	6.1	5.8	5.6	5.3	4.9	30	
32	6.7	6.5	6.2	6.0	5.7	5.3	5.0	32	
34	6.6	6.6	6.3	6.0	5.8	5.4	5.1	34	
36	6.4	6.5	6.4	6.1	5.9	5.5	5.1	36	
38	6.3	6.3	6.3	6.2	5.9	5.6	5.2	38	
40	6.1	6.2	6.2	6.2	6.0	5.6	5.2	40	
42	6.0	6.0	6.0	6.1	6.1	5.7	5.3	42	
44	5.8	5.9	5.9	6.0	6.0	5.8	5.4	44	
46	5.7	5.8	5.8	5.8	5.9	5.9	5.4	46	
48	5.6	5.6	5.7	5.7	5.8	5.8	5.5	48	
50	5.4	5.5	5.6	5.6	5.6	5.7	5.5	50	
52	5.3	5.4	5.5	5.5	5.5	5.6	5.5	52	
54	5.2	5.3	5.3	5.4	5.4	5.4	5.3	54	
56	5.1	5.2	5.2	5.2	5.1	5.0	4.8	56	
58	5.0	5.1	5.0	4.8	4.7	4.6	4.4	58	
60	4.9	4.8	4.6	4.5	4.4	4.2	4.1	60	
62	4.6	4.4	4.3	4.1	4.0	3.9	3.7	62	
64	4.2	4.1	3.9	3.8	3.7	3.5	3.4	64	
66	3.9	3.8	3.6	3.5	3.4	3.2	3.1	66	
68	3.6	3.5	3.3	3.2	3.1	2.9	2.8	68	
70	3.3	3.2	3.0	2.9	2.8	2.6	2.5	70	
72	3.0	2.9	2.8	2.6	2.5	2.4	2.2	72	
74		2.6	2.5	2.4	2.3	2.1		74	
76		2.4	2.3	2.1	2.0			76	
78			2.0					78	
Counterweight	54+20	54+20	54+20	54+20	54+20	54+20	54+20	Counterweight	
Rate	1	1	1	1	1	1	1	Rate	

## Notes:

1. The actual lifting weight is equal to the value that the rated lifting weight in the table subtracts the weight of all the lifting devices such as lifting hook
2. The rated lifting weight in the table is the weight of the non-traveling weight which is lifted slowly and steadily from the hard level ground.



**Quality Changes the World**

**SANY GROUP CO., LTD.**

Address: SANY Industrial Park, Economic and Technological  
Development Zone, Changsha, Hunan, China

Service Hotline: +0086-4006-098-318

E-mail: [crd@sany.com.cn](mailto:crd@sany.com.cn)

For more information, please visit: [www.sanygroup.com](http://www.sanygroup.com)

